

Hitachi Air Circuit Breakers AKN, AKS, AKH series



Air Circuit Breakers

Contents:

Overview	4
External configuration	10
Internal configuration	12
Ordering	14
Ratings	18
Trip relays	22
Accessories	48
Electrical diagram	78
Dimensions	80
Technical information	
· Insulation voltage	102
· Temperature derating	103
· Operating conditions	104
· Time chart	105
Ordering sheet	108

Premium ACB meets your demands for high breaking capacity, fully line-up, and optimized panel size.

Various accessories and connection methods realize user-friendly handling.

ACB provides you with total solutions with an advanced trip relay for measurement, diagnosis, analysis, and communication as well as protective functions for absolute protective coordination and electric power monitoring system.

Full line-up & Compact

Up to 6300A, ACB provides fully lined-up 3 frame.
For each frame, there is just one size, which is smaller and more compact. It makes it possible for you to design the optimized volume panel.



85kA 100kA 150kA

AKH-06 – 20D

06	630AF
08	800AF
10	1000AF
13	1250AF
16	1600AF
20	2000AF

$I_{cu} = I_{cs} = 85kA/500Vac$
W=334(3p), 419(4p)mm

AKH-06 – 40E

06	630AF	20	2000AF
08	800AF	25	2500AF
10	1000AF	32	3200AF
13	1250AF	40	4000AF
16	1600AF		

$I_{cu} = I_{cs} = 100kA/500Vac$
W=412(3p), 527(4p)mm

- The highest breaking capacity: 150kA (6300AF at 500VAC)
- 3 ampere frame sizes: 2000/4000/6300AF
- N phase current conducting capacity: 100%

AKH-40 – 63G

40	4000AF
50	5000AF
63	6300AF

$I_{cu} = I_{cs} = 150kA/500Vac$
W=785(3p), 1015(4p)mm

Trip relay



- L/S/I/G/Thermal
- Self Power
- RTC Timer mounted
- Fault information (LED)



- L/S/I/G/Thermal
- ZSI
- Remote Reset
- Modbus/RS-485
- Profibus-DP
- Self Power
- AC/DC 100 – 250V
- DC 24 – 60V
- RTC Timer mounted
- Fault Recording (10EA)



- L/S/I/G/Thermal (Continuous)
- US/OV/OF/RF/rPM/un/un
- Measurement: V/A/W/Wh/F/PF
- Harmonics (63th), Waveform (S Type)
- ZSI
- Remote Reset
- Modbus/RS-485
- Profibus-DP
- AC/DC 100 – 250V
- DC 24 – 60V
- RTC Timer mounted
- Event Recording (250EA)
- Fault Recording (250EA)
- Fault Wave (S Type)

Trip relays series



- N Type (Normal)**
- Self-power + Current protection



- P Type (Power Meter)**
- A type + Power Meter + Voltage/Frequency/Unbalance protection



- A Type (Ammeter)**
- Current Meter + Current protection + DO control + Communication



- S Type (Supreme)**
- P type + Harmonics analysis (63 th) + Fault wave recording

Accessories

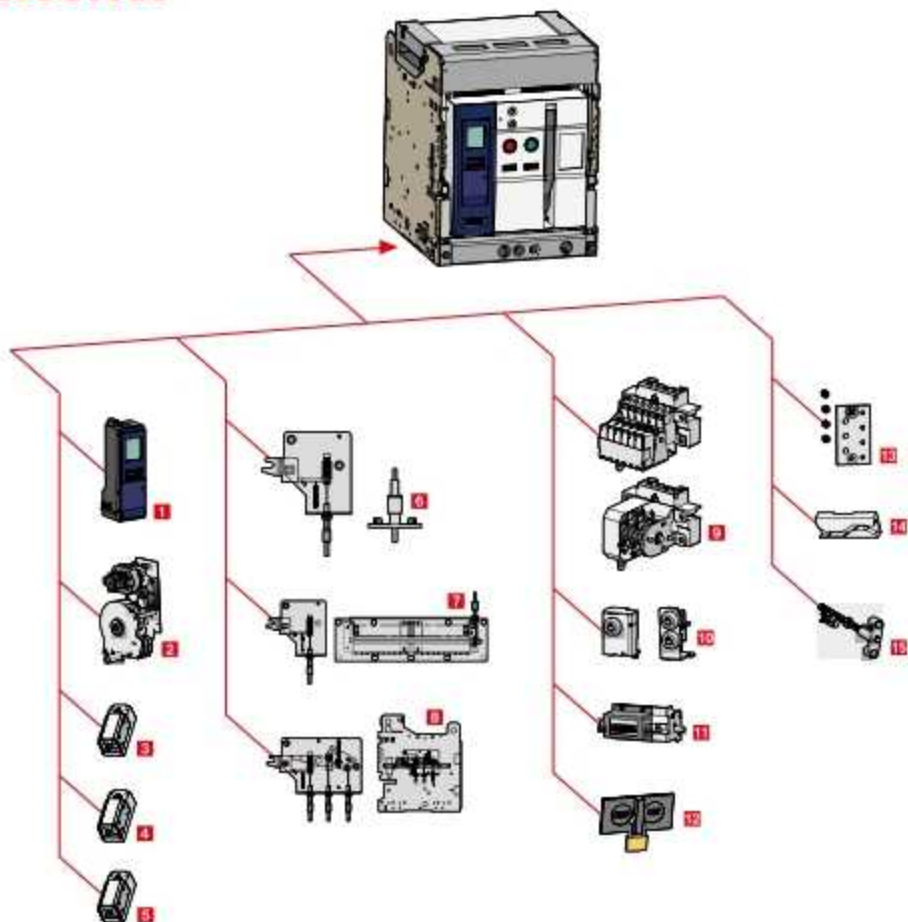

ACB

- | | |
|--|---|
| 1 Trip relay (OCR) | 9 Auxiliary Switch (AX) |
| 2 Motor (M) | 10 Key Lock (K1), Double Key Lock (K3) |
| 3 Closing Coil (CC) | 11 Counter (C) |
| 4 Shunt Coil (SHT) | 12 On/Off Button Lock (B) |
| 5 Under Voltage Trip Device (UVT) | 13 Miss Insertion Preventing Device (MIP) |
| 6 Door Interlock (DI) | 14 Automatically Discharge Mechanism (ADM) |
| 7 MOC (Mechanically Operated Cell Switch) | 15 Manual Reset Button (MRB) |
| 8 Mechanical Interlock (MI) | |

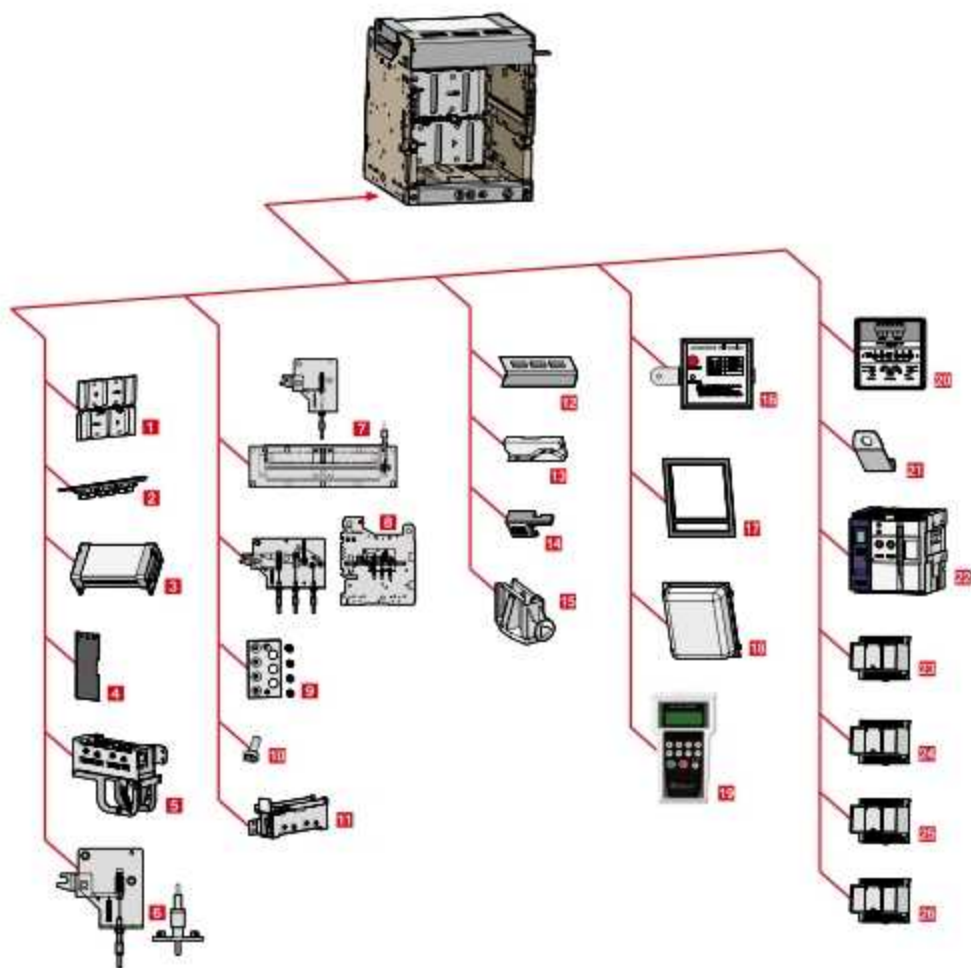

Cradle

- 1 Safety Shutter (ST)
- 2 Manual Connector
- 3 Zero Arc Space (ZAS)
- 4 Insulation Barrier (IB)
- 5 Cell Switch (CEL)
- 6 Door Interlock (DI)
- 7 MOC (Mechanically Operated Cell Switch)

- 8 Mechanical Interlock (MI)
- 9 Miss Insertion Prevent Device (MIP)
- 10 Cradle Mounting Block (CMB)
- 11 Shorting "b" Contact (SBC)
- 12 Safety Control Cover (SC)
- 13 Automatically Discharge Mechanism (ADM)
- 14 Racking Interlock (RI)
- 15 Safety Shutter Lock (STL)

Others

- 16 Condenser Trip Device (CTD)
- 17 Door Frame (DF)
- 18 Dust Cover (DC)
- 19 OCR Tester (OT)
- 20 ATS Controller (ATS)
- 21 Lifting Hook (LH)
- 22 Dummy ACB
- 23 UVT Time Delay Controller (UDC)
- 24 Profibus-DP Communication module
- 25 Remote I/O
- 26 Temperature Alarm

Multiple connections

Various installation methods

Standard connection



Horizontal type



Vertical type



Front type

Mixed connection



Horizontal/Vertical type



Vertical/Horizontal type



Horizontal/Front type



Vertical/Front type



Front/Horizontal type



Front/Vertical type

- Front connection type is available to be connected regardless of the depth of main circuit terminal, and it is suited for the panel required for limited installation space.
- The vertical and horizontal type terminal are module types which can easily compose the vertical and horizontal terminals by rotating 90°
Vertical and horizontal terminals are different each other for over 3200AF ACBs

Please refer to the rating lists (Page 18 ~ 21) because the installation method is various according to the rated current.

External configuration

Fixed type ACB



Terms

- ① Trip relay
- ② Counter
- ③ ON button
- ④ OFF button
- ⑤ Charge handle
- ⑥ Rated name plate
- ⑦ Charge/Discharge indicator
- ⑧ ON/OFF indicator
- ⑨ Corporation logo
- ⑩ Arc cover
- ⑪ Terminal cover
- ⑫ Cradle
- ⑬ Draw-out handle
- ⑭ Position indicator
- ⑮ Handle storage space
- ⑯ Pad lock button
- ⑰ Art chute
- ⑱ Control cover
- ⑲ Fixed type bracket

Draw-out ACB (Cradle)



Cradle (Internal)

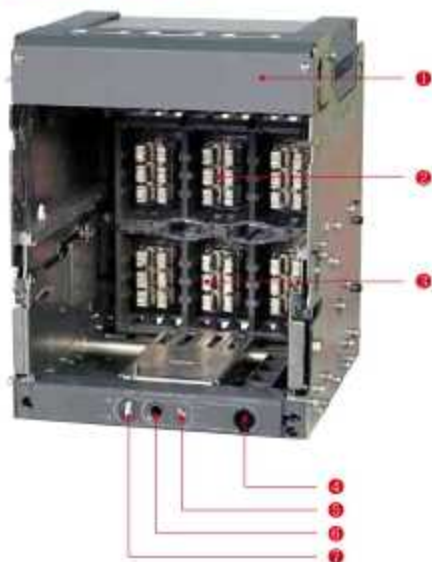

Terms

- ❶ Terminal cover of control circuit
- ❷ Cradle finger (Line side)
- ❸ Cradle finger (Load side)
- ❹ Draw-out handle
- ❺ Position indicator
- ❻ Handle storage space
- ❼ Pad lock button
- ❽ Connecting conductor (Line side)
- ❾ Connecting conductor (Load side)

Cradle (Rear)

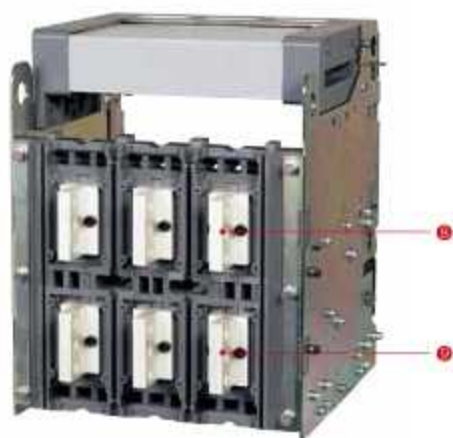

Internal configuration

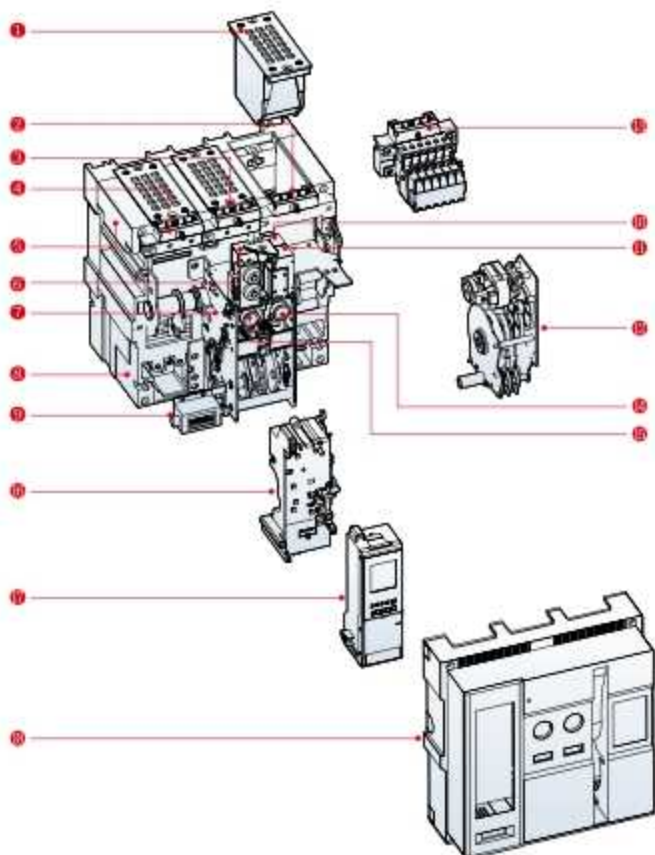

Terms

- 1 Arc chute
- 2 Aux. switch control terminal
- 3 Control power supply terminal
- 4 Trip relay control terminal
- 5 Carrying grip
- 6 Trip coil or UVT coil
- 7 Mechanism
- 8 Main body
- 9 Counter
- 10 Trip coil
- 11 Closing coil
- 12 Motor Ass'y
- 13 Aux. switch
- 14 ON button
- 15 OFF button
- 16 MTD base
- 17 Trip relay
- 18 Front cover



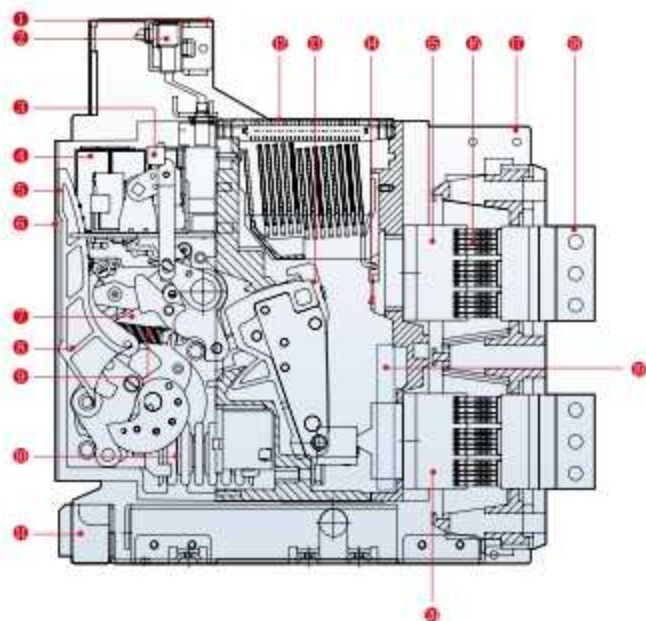

Terms

- 1 Control circuit terminal block
- 2 Control terminal
- 3 Auxiliary switches
- 4 Closing, Trip, UVT coil
- 5 Trip relay
- 6 Front cover
- 7 Mechanism
- 8 Charge handle
- 9 Trip spring
- 10 Closing spring
- 11 Draw-in/out device
- 12 Arc extinguishing part
- 13 Moving contact
- 14 Fixed contact
- 15 Conductor on line side
- 16 Cradle finger
- 17 Cradle
- 18 Connecting conductor
- 19 Power supply CT
- 20 Conductor on load side



Ordering

ACB & Accessories

AKH

10

D

3

10

J

Type
AKH
AKS
AKN



Ampere frame	Frame size & phase array
-	-
06 630AF	D 3P/4P Standard type RST (N)
08 830AF	D
10 1000AF	W 4P Reverse phase type NRST
13 1250AF	W
16 1600AF	W
20 2000AF	W

Nos. of pole
3 3P (D)
4 4P (D, W)

Rated current (CT Spec.)
00 Without OCR & CT
02 200A
04 400A
06 630A
04 400A
06 630A
08 800A
10 1000A
13 1250A
16 1600A
20 2000A

Connections
Draw-out type
J Manual connection
A Automatic connection
Fixed type
H Horizontal type
V Vertical type
Mixed type
M Line: Horizontal Load: Vertical
N Line: Vertical Load: Horizontal
F Front type



Ampere frame	Frame size & phase array
20 2000AF	D 3P/4P Standard type RST (N)
25 2500AF	W 4P Reverse phase type NRST
32 3200AF	W
40 4000AF	W

Nos. of pole
3 3P (E)
4 4P (E, X)

06 630A
08 800A
10 1000A
13 1250A
16 1600A
20 2000A
25 2500A
32 3200A
40 4000A



Ampere frame	Frame size & phase array
40 4000AF	D 3P/4P Standard type RST(N)
50 5000AF	W 4P Reverse phase type NRST

Nos. of pole
3 3P (F)
4 4P (F, Y)

40 4000A
50 5000A



Ampere frame	Frame size & phase array
40 4000AF	D 3P/4P Standard type RST(N)
50 5000AF	W 4P Reverse phase type NRST
63 6300AF	W

Nos. of pole
3 3P (G)
4 4P (G, Z)

40 4000A
50 5000A
63 6300A

M1**D1****D1****AX****NG0****U1****AL****Motor rated voltage**

MA	Without Motor
M1	AC/DC 100 – 130V
M2	AC/DC 200 – 250V
M3	DC 125V
M4	DC 24 – 30V
M5	DC 48 – 60V
M6	AC 380 – 415V
M7	AC 440 – 480V
M8	AC 48V

Shunt coil rated voltage

D0	Without Shunt coil
D1	AC/DC 100 – 130V
D2	AC/DC 200 – 250V
D3	DC 125V
D4	DC 24 – 30V
D5	DC 48 – 60V
D6	AC 380 – 480V
D7	AC 48V

Trip relay

Refer to 22 page

Closing coil rated voltage

D0	Without Closing coil
D1	AC/DC 100 – 130V
D2	AC/DC 200 – 250V
D3	DC 125V
D4	DC 24 – 30V
D5	DC 48 – 60V
D6	AC 380 – 480V
D7	AC 48V

Closing coil rated voltage

AX	Standard OFF-Charge 3a3b
AC	Standard ON-Charge 3a3b
BX	Standard OFF-Charge 5a5b
BC	Standard ON-Charge 5a5b
HX	High capacity OFF-Charge 3a3b
HC	High capacity ON-Charge 5a5b
CC	Standard ON-Charge 6a6b
JC	High capacity ON-Charge 6a6b

UVT coil rated voltage

U0	Without UVT coil
U1	AC/DC 100 – 130V
U2	AC/DC 200 – 250V
U3	DC 125V
U4	DC 24 – 30V
U5	DC 48 – 60V
U6	AC 380 – 480V
U7	AC 48V

*UVT Delay module is available only AC/DC 48V

Accessories

AL	AL1 + MRB	Trip alarm contact 1a + Manual reset button
A2	AL1 + AL2 + MRB	Trip alarm contact 2a + Manual reset button
A3	AL1 + MRB + RES (AC/DC 100 – 130V)	Trip alarm contact 1a + Manual reset button + Remote reset switch
A4	AL1 + MRB + RES (AC/DC 200 – 250V)	Trip alarm contact 1a + Manual reset button + Remote reset switch
A5	AL1 + MRB + Auto reset	AL + Auto reset type
A6	AL1 + AL2 + MRB + Auto reset	A2 + Auto reset type
A7	AL1 + MRB + RES (AC/DC 100 – 130V) + Auto reset	A3 + Auto reset type
AB	AL1 + MRB + RES (AC/DC 200 – 250V) + Auto reset	A4 + Auto reset type
C	C	Counter
S	CS2	Change switch communication
B	B	ON/OFF button lock
M	MI	Mechanical interlock
D	DI or MOC	Door interlock or Mechanical Operated Cell Switch
K	K1	Key Lock
K2	K2	Key Interlock set
K3	K3	Key Lock double
R	RCS	Ready to close switch
T	TM	Temperature Alarm
H	SHT2	Double Shut Coil

*Based on UVT and SHT2 are alternative.

2. Other accessories should be ordered separately. (Refer to 48 page)

Ordering

Cradle

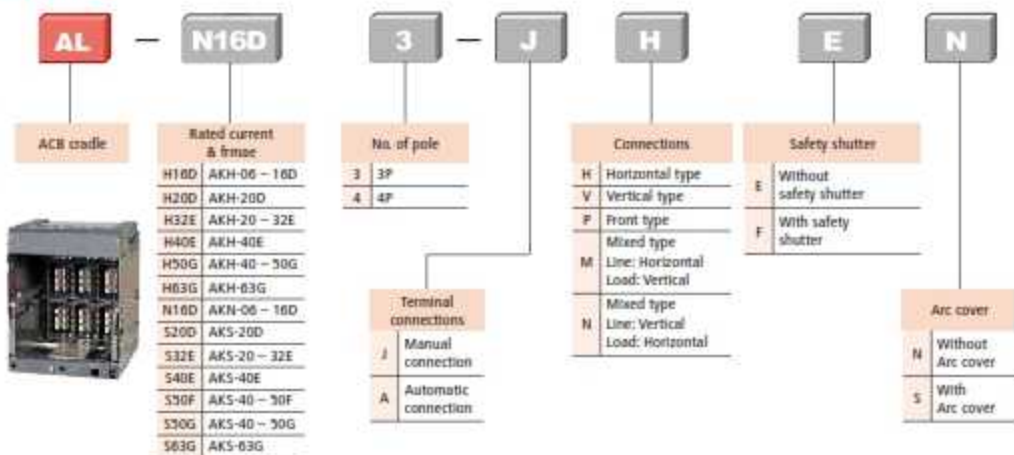

Rating



Type		AKH-06D	AKH-08D	AKH-10D	AKH-13D	AKH-16D	AKH-20D
Ampere frame	(AF)	630	800	1000	1250	1600	2000
Rated current (A)	(In max) at 40°C	200 400 630	400 630 800	1000	1250	1600	2000
Setting current (A)*	Control trip relay (... x In max)	(0.4 – 1.0) x In max					
Rated current of neutral pole (A)		400 630	400 630 800	1000	1250	1600	2000
Rated insulation voltage (V)	(Ui)	1,000					
Rated operating voltage (V)	(Ue)	690					
Rated impulse withstand voltage (kV)	(Uimp)	12					
Frequency (Hz)		50/60					
Number of poles (P)		3, 4					
Rated breaking capacity (kA sym)		220V/230V/380V/415V 480V/480V/500V					
AC 50/60Hz	(Icu)	IEC 60947-2 JISC 8201-2-1					
Rated service breaking capacity (kA)	(Ics)	...% x Icu					
Rated making capacity (kA peak)		220V/230V/380V/415V 480V/480V/500V					
AC 50/60Hz	(Icm)	IEC 60947-2 JISC 8201-2-1					
Rated short-time withstand current (kA)	(Icw)	1 sec 2 sec 3 sec					
Operating time (ms)		Maximum total breaking time Maximum closing time					
Life cycle (time)		Mechanical Without maintenance With maintenance					
		Electrical Without maintenance With maintenance					
Connections**		Draw-out / Fixed Horizontal connection Vertical connection Front connection Mixed connection					
Weight (kg) (3P/4P)		Draw-out type Main body (With cradle) Cradle only Fixed type Motor charging type Manual charging type					
External dimensions (mm) (H x W x D)		Draw-out type 3P 4P Fixed type 3P 4P					
Trip relay		N, A, P, S type					
Certificate & Approval		KEMA					

* Refer to trip relay specification. ** ● Contact ○ No Contact



AKH-06E	AKH-08E	AKH-10E	AKH-12E	AKH-16E	AKH-20E	AKH-25E	AKH-32E	AKH-40E
630	800	1000	1250	1600	2000	2500	3200	4000
630	800	1000	1250	1600	2000	2500	3200	4000
(0.4 – 1.0) x In max								
630	800	1000	1250	1600	2000	2500	3200	4000
1,000								
690								
12								
50/60								
3, 4								
100								
100								
85								
100%								
220								
220								
187								
85								
75								
65								
40								
80								
15,000								
20,000								
5,000								
10,000								
●								○
○								●
○								-
○								-
87/103						104/147		
85/101						102/145		
44/55						58/70		
44/55						63/100		
42/53						61/98		
430 x 412 x 375								
430 x 527 x 375								
300 x 378 x 295								
300 x 493 x 295								
N, A, P, S type								
KEMA								

AKH-40G	AKH-50G	AKH-63G
4000	5000	6300
4000	5000	6300
(0.4 – 1.0) x In max		
4000	5000	6300
1,000		
690		
12		
50/60		
3, 4		
150		
150		
100		
100%		
330		
330		
220		
100		
100		
40		
80		
10,000		
15,000		
2,000		
5,000		
○		●
●		○
-		-
-		-
181/223		186/230
179/221		184/228
97/117		102/124
98/123		103/130
96/121		101/128
460 x 785 x 375		
400 x 1,015 x 375		
300 x 751 x 295		
300 x 981 x 295		
N, A, P, S type		
KEMA		

Rating



Type			AKN-060	AKN-080	AKN-100	AKN-130	AKN-160	AKS-200
Ampere frame	(AF)		630	800	1000	1250	1600	2000
Rated current (A)	(In max)	at 40°C	200 400 630	400 630 800	1000	1250	1600	2000
Setting current (A)*	Control trip relay (... x In max)		[0.4 – 1.0] x In max					
Rated current of neutral pole (A)			400 630	400 630 800	1000	1250	1600	2000
Rated insulation voltage (V)	(Ui)		1,000					
Rated operating voltage (V)	(Ue)		690					
Rated impulse withstand voltage (kV)	(Uimp)		12					
Frequency (Hz)			50/60					
Number of poles (P)			3, 4					
Rated breaking capacity (kA sym)			220V/230V/380V/415V 460V/480V/500V					
AC 50/60Hz	(Icu)	IEC 60947-2 JIS C 8201-2-1	65 65 50					
Rated service breaking capacity (kA)	(Ics)		..% x Icu 100%					
Rated making capacity (kA peak)			220V/230V/380V/415V 480V/480V/500V					
AC 50/60Hz	(Icm)	IEC 60947-2 JIS C 8201-2-1	143 143 105					
Rated short-time withstand current (kA)	(Icw)		1 sec 2 sec 3 sec					
			50 42 36					
Operating time (ms)			Maximum total breaking time Maximum closing time					
			40 80					
Life cycle (time)			Mechanical Electrical					
			Without maintenance With maintenance Without maintenance With maintenance					
			20,000 30,000 3,000 10,000					
Connections**			Draw-out /Fixed Horizontal connection Vertical connection Front connection Mixed connection					
			● ○ ○ ○					
Weight (kg)			3P/4P					
			Draw-out type Main body (With cradle) Cradle only Fixed type					
			Motor charging type Manual charging type Motor charging type Manual charging type					
			63/74 61/72 29/32 34/44 32/42					
			70/85 68/83 33/40 38/47 36/45					
External dimensions (mm)			(H x W x D)					
			Draw-out type Fixed type					
			3P 4P 3P 4P					
			430 x 334 x 375 430 x 419 x 375 300 x 300 x 295 300 x 385 x 295					
Trip relay			K, A, F type					
Certificate & Approval			KEMA					

*Refer to the relay specification. ** ●: Standard ○: Option



AKS-20E	AKS-25E	AKS-32E	AKS-40E
2000	2500	3200	4000
630, 800			
1000, 1250	2500	3200	4000
1600, 2000			
(0.4 – 1.0) x In max			
630, 800			
1000, 1250	2500	3200	4000
1600, 2000			
1,000			
690			
12			
50/60			
3, 4			
85			
85			
85			
100%			
187			
187			
187			
85			
75			
65			
40			
80			
15,000			
20,000			
5,000			
10,000			
●			○
○			●
○			-
○			-
87/103			104/147
85/101			102/145
44/50			58/70
44/55			63/100
42/53			61/98
430 x 412 x 375			
430 x 527 x 375			
300 x 378 x 295			
300 x 493 x 295			
N, A, P type			
KEMA			

AKS-50F	
4000	5000
4000	5000
(0.4 – 1.0) x In max	
4000	5000
1,000	
690	
12	
50/60	
3, 4	
100	
100	
85	
100%	
220	
220	
187	
85	
75	
65	
40	
80	
10,000	
15,000	
2,000	
5,000	
○	○
●	●
-	-
-	-
145/173	181/223
143/171	179/221
78/90	97/117
76/94	98/123
74/92	96/121
460 x 629 x 375	
460 x 799 x 375	
300 x 597 x 295	
300 x 767 x 295	
N, A, P type	
KEMA	

AKS-40G	AKS-50G	AKS-63G
4000	5000	6300
4000	5000	6300
(0.4 – 1.0) x In max		
4000	5000	6300
1,000		
690		
12		
50/60		
3, 4		
120		
120		
100		
100%		
264		
264		
220		
100		
90		
85		
40		
80		
10,000		
15,000		
2,000		
5,000		
○		
○		
○		
○		
181/223	186/230	
179/221	184/228	
97/117	102/124	
98/123	103/130	
96/121	101/128	
460 x 785 x 375		
400 x 1,015 x 375		
300 x 751 x 295		
300 x 981 x 295		
N, A, P type		
KEMA		

Trip relay (OCR)

The trip relay of ACB provides the additional protection functions for voltage, frequency, unbalance, and others in addition to main protection functions for over current, short-circuit, ground fault. It supports the advanced measurement functions for voltage, current, power, electric energy, harmonics, communication function, and others.

Analog trip function interlocked with mechanism enhanced a durability of devices as well as the breaking capacity of ACB.

Zone selective interlocking function makes the protective coordination more simple and thermal memory can be applied to various loads.



Contents

Trip relay types	23
N type: Normal type	24
A type: Ammeter type	26
P type: Power meter type	28
S type: Supreme meter type	30
Operation characteristic	32
Measurement function	34
Man machine interface	35
Protection element setting	36
Measurement element display	37
Characteristic curves	38
ZSI – Zone Selective Interlocking	43
Remote reset and digital I/O	44
Communication	45
Event & fault recording	46
System block diagram	47

Trip relays

Trip relay types

Classification	N type	A type	P type	S type
Externals				
Current protection	L/S//G/Thermal	- L/S//G/Thermal - ZSI (Protective coordination)	- L/S//G/Thermal (Continuous) - ZSI (Protective coordination)	- P type
Other protection	-	- Earth leakage (Option)	- Earth leakage (Option) - Over/ Under current - Over/ Under frequency - Unbalance (Voltage/ Current) - Reverse power	- P type
Measurement function	-	- Current (R/S/T/N)	- 3 Phase Voltage/ Current RMS/ Vector - Power (P, Q, S), PF (3-Phase) - Energy (Positive/Negative) - Frequency, Demand	- 3 Phase Voltage/ Current RMS/ Vector - Power (P, Q, S), PF (3-Phase) - Energy (Positive/Negative) - Frequency, Demand - Voltage/ Current harmonics (1st – 63th) - 3 Phase Waveforms - THD, TDD, K-Factor
Fine adjustment	-	-	- Fine adjustment for long/short time delay/ instantaneous/ground	- P type
Pre Trip Alarm	-	-	- Overload protection relays: DO (Alarm) (Ground fault is not available when using Pre trip alarm)	- P type
Digital Output	-	- 3DO (Fixed) - L, S/I, G Alarm	- 3DO (Programmable) - Trip, Alarm, General	- P type
IDMTL setting	-	-	- Compliance with IEC60255-3 - SIT, VIT, EIT, DT	- P type
Communication	-	- Modbus/RS – 485 - Profibus – DP	- Modbus/RS – 485 - Profibus – DP	- Modbus/RS – 485 - Profibus – DP
Power supply	- Self Power - Power source works over 20% of load current.	- Self Power - Power source works over 20% of load current. - External power source are required for comm. - AC/DC 100 – 250V - DC 24 – 60V	- AC/DC 100 – 250V - DC 24 – 60V	- AC/DC 100 – 250V - DC 24 – 60V
RTC timer	- Available	- Available	- Available	- Available
LED for trip info.	- Long time delay - Short time delay/instantaneous - Ground fault	- N type	- N type	- N type
Fault recording	-	- 10 records (Fault/ Current/Date and Time)	- 256 records (Fault/ Current/ Date and Time)	- 256 records - Last fault wave recording (3 Phase)
Event recording	-	-	- 256 records (Content, Status, Date)	- P type
Operating button	- Reset button	- Reset, Menu Up/Down, Left/ Right, Enter	- A type	- A type

Basic protection function (L/S//G) is still under normal operation without control power.

Trip relays

N type: Normal type

- Optimized protection function
- OCR, OCGR function according to IEC60947-2
- Overload protection
 - Long-time delay
 - Thermal
- Short-circuit protection
 - Short-time delay / Instantaneous
 - I't On / Off optional (for short-time delay)
- Ground fault protection
 - I't On / Off optional
- Self - Power



① LED: Indication of trip info. and overload state



- Ig: LED indicating ground-fault
- Ist/I: LED indicating short-time or instantaneous tripping
- I: LED indicating long-time delay
- SP: Self-protection and battery test LED
- Alarm: LED indicating an overload
(Turn on above 90%, Blink above 105%)

② Reset key: Fault reset or battery check

③ Iu, Ir: Long-time current setting, tr: Long-time tripping delay setting

④ Ist: Short-time current setting, tsd: Short-time tripping delay setting

⑤ Ii: Instantaneous current setting

⑥ Ig: Ground fault current setting, tg: Ground fault tripping delay setting

⑦ Test terminal: OCR test terminal (Connected with OCR tester)



Protection

Long time

Current setting (A)	$I_u = I_n \times \dots$	0.3	0.6	0.7	0.8	0.9	1.0		
	$I_r = I_u \times \dots$	0.8	0.83	0.85	0.88	0.9	0.93	0.95	0.98
Time delay (s)	$t_r \text{ @ } (1.5 \times I_r)$	12.5	25	50	100	200	300	400	500
Accuracy: $\pm 15\%$ or below	$t_r \text{ @ } (6.0 \times I_r)$	0.5	1	2	4	8	12	16	20
100ms	$t_r \text{ @ } (7.2 \times I_r)$	0.34	0.69	1.38	2.7	5.5	8.3	11	13.8

Short time

Current setting (A)	$I_{sd} = I_r \times \dots$	1.5	2	3	4	5	6	8	10
Accuracy: $\pm 10\%$									Off
Time delay (s) $\text{ @ } 10 \times I_r$	$I^2 t$ Off	0.05	0.1	0.2	0.3	0.4			
	$I^2 t$ On		0.1	0.2	0.3	0.4			
$(I^2 t)$ Off	Min. Trip Time (ms)	20	80	160	260	360			
	Max. Trip Time (ms)	80	140	240	340	440			

Instantaneous

Current setting (A)	$I = I_n \times \dots$	2	3	4	6	8	10	12	15
Tripping time		below 50ms							

Ground fault

Pick-up (A)	$I_g = I_n \times \dots$	0.2	0.3	0.4	0.5	0.6	0.7	0.8	1.0
Accuracy: $\pm 10\%$ ($I_g > 0.4 I_n$)									
$\pm 20\%$ ($I_g \leq 0.4 I_n$)									
Time delay (s) $\text{ @ } 1 \times I_n$	$I^2 t$ Off	0.05	0.1	0.2	0.3	0.4			
	$I^2 t$ On		0.1	0.2	0.3	0.4			
$(I^2 t)$ Off	Min. Trip Time (ms)	20	80	160	260	360			
	Max. Trip Time (ms)	80	140	240	340	440			



Trip relays

A type: Ammeter type

- Overload protection
 - Long-time delay
 - Thermal
- Short-circuit protection
 - Short-time delay/Instantaneous
 - I't On/Off optional (for short-time delay)
- Ground fault protection
 - I't On/Off optional
- Realization of protective coordination by ZSI (Zone Selective Intenerlocking)
- High-performance and high-speed MCU built-in
 - Accurate measurement with tolerance of 1.0%
- Fault recording
 - Records Max. up to 10 fault information about fault type, fault phase, fault data, occurrence time of fault
- SBO (Select Before Operation)
 - High reliability for control and setting change method
- 3 DO (Digital Output)
 - Fixed
- Communication
 - Modbus/RS485
 - Profibus-DP



① LCD: Indication of measurement and information

② LED: Indication of trip info. and overload state



- Ig: LED Indicating ground-fault
- Isd/Ii: LED Indicating short-time or instantaneous tripping
- Ii: LED Indicating long-time delay
- SP: Self-protection and battery test LED
- Alarm: LED Indicating an overload (Turn on above 90%, Blink above 105%)

③ Key: Move to menu or reset



- Reset/ESC: Fault reset or ESC from menu
- Enter: Enter Into secondary menu or setting input
- Up/Down: Move the cursor up/down on scree or increase/decrease a setting value
- Right/Left: Move the cursor or setting right/left on screen (Rotation)
- Menrc: Menu display — Measurement display

④ Iu, Ii: Long-time current setting, tr: Long-time tripping delay setting

⑤ Isd, Ii: Short-time current setting, tsd: Short-time tripping delay setting

⑥ Ii: Instantaneous current setting

⑦ Ig: Ground fault current setting, tg: Ground fault tripping delay setting

⑧ Test terminal: OCR test terinal (Connected with OCR tester)

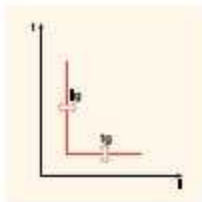

Protection

Long time											
Current setting (A)	$I_u = I_n \times \dots$	0.5	0.6	0.7	0.8	0.9	1.0				
	$I_r = I_u \times \dots$	0.8	0.83	0.85	0.88	0.9	0.93	0.95	0.98	1.0	
Time delay (s)	$t_r @ (1.5 \times I_r)$	12.5	25	50	100	200	300	400	500	Off	
Accuracy: $\pm 15\%$ or below 100ms	$t_r @ (5.0 \times I_r)$	0.5	1	2	4	8	12	16	20	Off	
	$t_r @ (7.2 \times I_r)$	0.34	0.69	1.38	2.7	5.5	8.3	11	13.8	Off	
Short time											
Current setting (A)	$I_{sd} = I_r \times \dots$	1.5	2	3	4	5	6	8	10	Off	
Accuracy: $\pm 10\%$											
Time delay (s) $\Phi 10 \times I_r$	t_{sd}	$I^2 t$ Off	0.05	0.1	0.2	0.3	0.4				
		$I^2 t$ On		0.1	0.2	0.3	0.4				
$(I^2 t$ Off)		Min. Trip Time (ms)	20	80	160	260	360				
		Max. Trip Time (ms)	80	140	240	340	440				
Instantaneous											
Current setting (A)	$I_s = I_n \times \dots$	2	3	4	6	8	10	12	15	Off	
Tripping time		below 50ms									
Ground fault											
Pick-up (A)											
Accuracy: $\pm 10\%$ ($I_g > 0.4 I_n$) $\pm 20\%$ ($I_g \leq 0.4 I_n$)	$I_g = I_n \times \dots$	0.2	0.3	0.4	0.5	0.6	0.7	0.8	1.0	Off	
Time delay (s) $\Phi 1 \times I_n$	t_g	$I^2 t$ Off	0.05	0.1	0.2	0.3	0.4				
		$I^2 t$ On		0.1	0.2	0.3	0.4				
$(I^2 t$ Off)		Min. Trip Time (ms)	20	80	160	260	360				
		Max. Trip Time (ms)	80	140	240	340	440				
Earth leakage (Optim)											
Current setting (A)	I_g	0.5	1	2	3	5	10	20	30	Off	
Time delay (ms)	t_g	Alarm Time (ms)	140	230	350	800	950				
		Trip Time (ms)	140	230	350	800					
Accuracy: $\pm 15\%$											

Note) Earth leakage function is available with ZCT or version CT

Trip relays

P type: Power meter type

- Overload protection
 - Long-time delay
 - Thermal
 - Short-circuit protection
 - Short-time delay/Instantaneous
 - I't On/Off optional (for short-time delay)
 - Ground fault protection
 - I't On/Off optional
 - Protection for Over voltage/Under voltage/Over frequency/Under frequency/Unbalance/Reverse power
 - Realization of protective coordination by ZSI (Zone Selective Interlocking)
 - The fine-adjustable setting by knob and Key
 - IDML setting (SIT, VIT, EIT, DT curve)
- Measurement and Display Function
 - High detailed measurement for 3 phase current/ Voltage/Power/Energy/Phase angle/Frequency/PF/Demand
 - 128 x 128 Graphic LCD
 - Indicates current/voltage/Vector Diagram and Waveform
 - Fault recording
 - Records Max. up to 256 fault information about fault type, fault phases, fault data, occurrence time of fault
 - Event recording
 - Records events of device related to setting change, operation and state change. (Max. up to 256)
 - SBO (Select Before Operation)
 - High reliability for control and setting change method
 - 3 DO (Digital Output)
 - Programmable for alarm, trip and general DO
 - Communication
 - Modbus/RS485
 - Profibus-DP



① Graphic LCD: Indication of measurement and information

② LED: Indication of trip info. and overload state



- Comm: LED indicating comm. state (Blink when running)
- Ig: LED indicating ground-fault
- I'd/I'i: LED indicating short-time or instantaneous tripping
- I'r: LED indicating long-time delay
- SP: Self-protection and battery test LED
- Alarm: LED indicating an overload (Turn on above 90%, Blink above 105%)

③ Key: Move to menu or reset



- Reset/ESC: Fault reset or ESC from menu
- Enter: Enter into secondary menu or setting input
- Up/Down: Move the cursor up/down on screen or Increase/decrease a setting value
- Right/Left: Move the cursor or setting right/left on screen (Rotation)
- Menu: Menu display — Measurement display

④ I'r: Long-time current setting, I'tr: Long-time tripping delay setting

⑤ I'sd: Short-time current setting, I'tsd: Short-time tripping delay setting

⑥ I'i: Instantaneous current setting

⑦ I'g: Ground fault current setting, I'tg: Ground fault tripping delay setting

⑧ Test terminal: OCR test terminal (Connected with OCR tester)

Protection

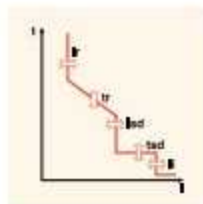

Long time										
Current setting (A)	$I = I_r \times \dots$	0.4	0.5	0.6	0.7	0.8	0.9	1.0		
Time delay (s)	$t_r @ (1.5 \times I_r)$	12.5	25	50	100	200	300	400	500	Off
Accuracy: $\pm 15\%$ or below	$t_r @ (6.0 \times I_r)$	0.5	1	2	4	8	12	16	20	Off
100ms	$t_r @ (7.2 \times I_r)$	0.34	0.69	1.38	2.7	5.5	8.3	11	13.8	Off

Short time										
Current setting (A)	$I_{sd} = I_r \times \dots$	1.5	2	3	4	5	6	8	10	Off
Accuracy: $\pm 10\%$										
Time delay (s) $\text{@} 10 \times I_r$	t_{sd}	I_r Off	0.05	0.1	0.2	0.3	0.4			
		I_r On		0.1	0.2	0.3	0.4			
$(I_r$ Off)	Min. Trip Time (ms)		20	80	160	260	360			
	Max. Trip Time (ms)		80	140	240	340	440			

Instantaneous										
Current setting (A)	$I = I_n \times \dots$	2	3	4	6	8	10	12	15	Off
Tripping time		below 50ms								

Ground fault										
Pick-up (A)										
Accuracy: $\pm 10\%$ ($I_g > 0.4In$)	$I_g = I_n \times \dots$	0.2	0.3	0.4	0.5	0.6	0.7	0.8	1.0	Off
	$\pm 20\%$ ($I_g < 0.4In$)									
Time delay (s) $\text{@} 1 \times I_n$	t_g	I_r Off	0.05	0.1	0.2	0.3	0.4			
		I_r On		0.1	0.2	0.3	0.4			
$(I_r$ Off)	Min. Trip Time (ms)		20	80	160	260	360			
	Max. Trip Time (ms)		80	140	240	340	440			

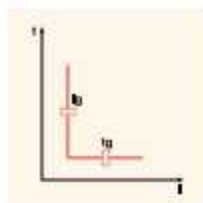

Earth leakage (Option)										
Current setting (A)	I_g	0.5	1	2	3	5	10	20	30	Off
Time delay (ms)	t_g	Alarm Time (ms)	140	230	350	800	950			
Accuracy: $\pm 15\%$		Trip Time (ms)	140	230	350	800				

Note) Earth leakage function is available with CT or voltage CT

PTA (Pre Trip Alarm)										
Current setting (A)	$I_p = I_r \times \dots$	0.6	0.65	0.7	0.75	0.8	0.85	0.9	0.95	1
Time delay (s)	$t_p @ (1.2 \times I_p)$	1	5	10	15	20	25	30	35	Off
Accuracy: $\pm 15\%$										

Other protection	Pick-up			Time delay (s)		
	Setting range	Step	Accuracy	Setting range	Step	Accuracy
Under voltage	80V - 0V_Pick-up	1V	$\pm 5\%$	1.2 - 40sec	0.1sec	$\pm 0.1sec$
Over voltage	UV_Pick-up - 980V	1V	$\pm 5\%$			
Voltage unbalance	6% - 99%	1%	$\pm 2.5\%$ or ($^* \pm 10\%$)			
Reverse power	10 - 500kW	1kW	$\pm 10\%$			
Over power	500 - 5,000kW	1kW	$\pm 10\%$			
Current unbalance	6% - 99%	1%	$\pm 2.5\%$ or ($^* \pm 10\%$)			
Over frequency	60Hz UF_Pick-up - 65	1Hz	$\pm 0.1Hz$	1.2 - 40sec		
	50Hz UF_Pick-up - 55	1Hz	$\pm 0.1Hz$			
Under frequency	60Hz 55Hz - OF_Pick-up	1Hz	$\pm 0.1Hz$			
	50Hz 45Hz - OF_Pick-up	1Hz	$\pm 0.1Hz$			

Trip relays

S type: Supreme meter type

- Overload protection
 - Long-time delay
 - Thermal
 - Short-circuit protection
 - Short-time delay/Instantaneous
 - I't On/Off optional (for short-time delay)
 - Ground fault protection
 - I't On/Off optional
 - Protection for Over voltage/Under voltage/Over frequency/Under frequency/Unbalance/Reverse power
 - Realization of protective coordination by ZSI (Zone Selective Interlocking)
 - The fine-adjustable setting by knob and Key
 - IDML setting (SIT, VIT, EIT, DT curve)
- Measurement and Display Function
 - High detailed measurement for 3 phase current / Voltage / Power / Energy / Phase angle / Frequency / PF / Demand
 - 128 x 128 Graphic LCD
 - Indicates current / voltage Vector Diagram and Waveform
 - Fault recording
 - Records Max. up to 256 fault information about fault type, fault phases, fault data, occurrence time of fault
 - Fault wave recording: records the latest fault wave
 - Event recording
 - Records events of device related to setting change, operation and state change. (Max. up to 256)
 - SBO (Select Before Operation)
 - High reliability for control and setting change method
 - Power quality analysis
 - Measurement for 1st – 63th harmonics
 - THD, TDD, k-Factor
 - 3 DO (Digital Output)
 - Programmable for alarm, trip and general DO
 - Communication
 - Modbus/RS485
 - Profibus-DP



① Graphic LCD: Indication of measurement and information

② LED: Indication of trip info. and overload state



③ Key: Move to menu or reset

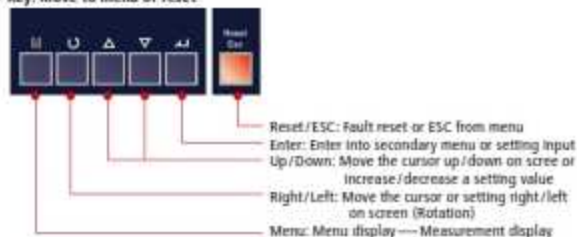

④I: Long-time current setting, tr: Long-time tripping delay setting

⑤I'd: Short-time current setting, t'd: Short-time tripping delay setting

⑥I'i: Instantaneous current setting

⑦I'g: Ground fault current setting, t'g: Ground fault tripping delay setting

⑧Test terminal: OCR test terminal (Connected with OCR tester)

Protection

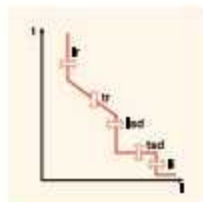

Long time										
Current setting (A)	$I_r = I_n \times \dots$	0.4	0.5	0.6	0.7	0.8	0.9	1.0		
Time delay (s)	$t_{td} \text{ @ } (1.5 \times I_r)$	12.5	25	50	100	200	300	400	500	Off
Accuracy: $\pm 15\%$ or below 100ms	$t_{td} \text{ @ } (6.0 \times I_r)$	0.5	1	2	4	8	12	16	20	Off
	$t_{td} \text{ @ } (7.2 \times I_r)$	0.34	0.69	1.38	2.7	5.5	8.3	11	13.8	Off

Short time										
Current setting (A)	$I_{sd} = I_r \times \dots$	1.5	2	3	4	5	6	8	10	Off
Accuracy: $\pm 10\%$										
Time delay (s) $\text{ @ } 10 \times I_r$	I^2t Off	0.05	0.1	0.2	0.3	0.4				
	I^2t On		0.1	0.2	0.3	0.4				
$(I^2t$ Off)	Min. Trip Time (ms)	20	80	160	260	360				
	Max. Trip Time (ms)	80	140	240	340	440				

Instantaneous										
Current setting (A)	$I_i = I_n \times \dots$	2	3	4	6	8	10	12	15	Off
Tripping time		below 50ms								

Ground fault										
Pick-up (A)										
Accuracy: $\pm 10\%$ ($I_g > 0.4I_n$)	$I_g = I_n \times \dots$	0.2	0.3	0.4	0.5	0.6	0.7	0.8	1.0	Off
	$\pm 20\%$ ($I_g < 0.4I_n$)									
Time delay (s) $\text{ @ } 1 \times I_n$	I^2t Off	0.05	0.1	0.2	0.3	0.4				
	I^2t On		0.1	0.2	0.3	0.4				
$(I^2t$ Off)	Min. Trip Time (ms)	20	80	160	260	360				
	Max. Trip Time (ms)	80	140	240	340	440				

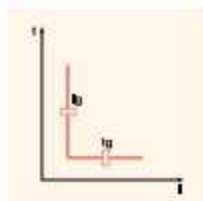

Earth leakage (Option)										
Current setting (A)	I_g	0.5	1	2	3	5	10	20	30	Off
Time delay (ms)	t_g	Alarm Time (ms)	140	230	350	800	950			
		Trip Time (ms)	140	230	350	800				
Accuracy: $\pm 15\%$										

Note: Earth leakage function is available with CT or voltage CT

PTA (Pre Trip Alarm)										
Current setting (A)	$I_p = I_r \times \dots$	0.6	0.65	0.7	0.75	0.8	0.85	0.9	0.95	1
Time delay (s)	$t_p \text{ @ } (1.2 \times I_p)$	1	5	10	15	20	25	30	35	Off
Accuracy: $\pm 15\%$										

Other protection	Pick-up			Time delay (s)		
	Setting range	Step	Accuracy	Setting range	Step	Accuracy
Under voltage	80V - 0V_Pick-up	1V	$\pm 5\%$	1.2 - 40sec	0.1sec	$\pm 0.1sec$
Over voltage	UV_Pick-up - 980V	1V	$\pm 5\%$			
Voltage unbalance	6% - 99%	1%	$\pm 2.5\%$ or ($^* \pm 10\%$)			
Reverse power	10 - 500kW	1kW	$\pm 10\%$			
Over power	500 - 5,000kW	1kW	$\pm 10\%$			
Current unbalance	6% - 99%	1%	$\pm 2.5\%$ or ($^* \pm 10\%$)			
Over frequency	60Hz UF_Pick-up - 65	1Hz	$\pm 0.1Hz$	1.2 - 40sec		
	50Hz UF_Pick-up - 55	1Hz	$\pm 0.1Hz$			
Under frequency	60Hz 55Hz - OF_Pick-up	1Hz	$\pm 0.1Hz$			
	50Hz 45Hz - OF_Pick-up	1Hz	$\pm 0.1Hz$			

Trip relays

Operation characteristic

Long-time delay (L)

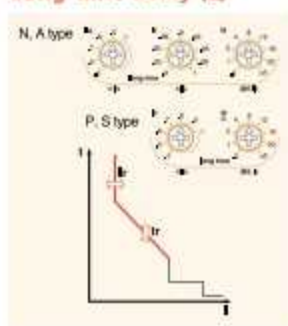

The function for overload protection which has time delayed characteristic in inverse ratio to fault current.

1. Standard current setting knob: I_r
 - 1) Setting range in P type and S type: $(0.4-0.5-0.6-0.7-0.8-0.9-1.0) \times I_n$
 - 2) Setting range in N type and A type: $(0.4 - 1.0) \times I_n$
 - I_u : $(0.5-0.6-0.7-0.8-0.9-1.0) \times I_n$
 - I_r : $(0.8-0.83-0.85-0.88-0.9-0.93-0.95-0.98-1.0) \times I_u$
2. Time delay setting knob: t_r
 - Standard operating time is based on the time of $6 \times I_r$
 - Setting range: 0.5-1-2-4-8-12-16-20-Off sec (9 modes)
3. Relay pick-up current
 - When current over $(1.15) \times I_r$ flows in, relay is picked up.
4. Relay operates basing on the largest load current amount R/S/T/N phase.

Short-time delay (S)

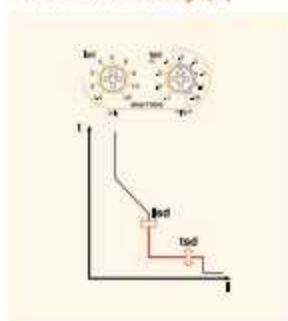

The function for fault current (over current) protection which has definite time characteristic and time delayed in inverse ratio to fault current.

1. Standard current setting knob: I_{sd}
 - Setting range: $(1.5-2-3-4-5-6-8-10-Off) \times I_r$
2. Time delay setting knob: t_{sd}
 - Standard operating time is based on the time of $10 \times I_r$
 - Inverse time (I^t On) : 0.1-0.2-0.3-0.4 sec
 - Definite time (I^t Off) : 0.05-0.1-0.2-0.3-0.4 sec
3. Relay operates basing on the largest load current amount R/S/T/N phase.
4. Relay can operate at instantaneous current through ZSI.

Instantaneous (I)

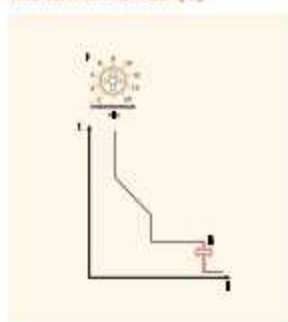

The function for breaking fault current above the setting value within the shortest time to protect the circuit from short-circuit.

1. Standard current setting knob: I_i
 - Setting range: $(2-3-4-6-8-10-12-15-Off) \times I_n$
2. Relay operates basing on the largest load current amount R/S/T/N phase.
3. Total breaking time is below 50ms.

Ground Fault (G)

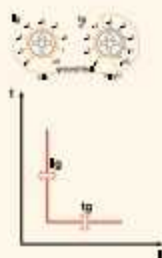

The function for breaking ground fault current above setting value after time-delay to protect the circuit from ground fault.

- Standard current setting knob: I_g
 - Setting range: $(0.2-0.3-0.4-0.5-0.6-0.7-0.8-1.0-Off) \times I_n$
- Time delay setting knob: t_g
 - Inverse time (I^t On) : 0.1-0.2-0.3-0.4 sec
 - Definite time (I^t Off) : 0.05-0.1-0.2-0.3-0.4 sec
- Ground fault current = R + S + T + N (Vector Sum)
- Relay can operate at instantaneous current through ZSI.
- The protection for ground fault is a basic function of Trip relay (Internal CT type)

Earth Leakage (G) - Option

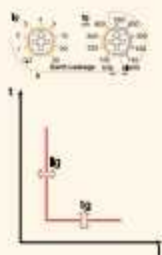

The function for breaking earth leakage current above setting value after time delay to protect the circuit from earth leakage. (A, P, S type)

- Standard current setting knob: I_g
 - Setting range: 0.5-1-2-3-4-5-10-20-30-Off (A)
- Time delay setting knob: t_g
 - Trip time: 140-230-350-800 ms
 - Alarm time: 140-230-350-800-950 ms
- It is only available with private ZCT or general purpose external CT.

* Notice in setting range

In case of using our ZCT all setting points from 0.5 to 30A, the secondary current of ZCT are available.

However if private ZCT is selected the setting range is limited to 0.5 – 5A.

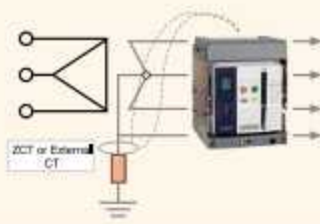

*The necessity of earth leakage relay with external CT

- Earth leakage relay with Internal CT (standard) operates in the range of 20% – 100% of the rated current.

- If the rated current of ACB increases, the standard operating current of earth leakage relay also increases.

ex) 400AF ACB of Min. earth leakage relay current, $400A \times 20\% = 80A$

4000AF ACB of Min. earth leakage relay current, $4000A \times 20\% = 800A$

- Thus, ACB provides a solution with CT which can be installed externally to adjust sensibility of earth leakage current which can operate relay. (separate purchase)

Trip relays

Measurement function

	Class.	Measurement element	Detailed element	Unit	Display range	Accuracy
A type	Current	Line current	I_a, I_b, I_c	A	80A – 65,535A	±2%
		Normal current	I_n			
		Reverse current	I_r			
Voltage	Line voltage	V_{ab}, V_{bc}, V_{ca}	V	60 – 690V	±1%	
	Phase voltage	V_a, V_b, V_c				
	Normal voltage	V_n				
	Reverse voltage	V_r				
Angle	Line-to-line	$\angle V_{ab/a}, \angle V_{ab/b}, \angle V_{ab/c},$ $\angle V_{ab/bc}, \angle V_{ab/vca}$	°	0 – 360°	±1°	
	Line-to-current					
	Phase-to-phase	$\angle V_{a/b}, \angle V_{a/c}$				
P Type	Power	Phase-to-current	$\angle V_{a/a}, \angle V_{b/b}, \angle V_{c/c}$	kW	1kW – 99,999kW	±2%
		Active power	$P_a(ab), P_b(bc), P_c(ca), P$			
		Reactive power	$Q_a(ab), Q_b(bc), Q_c(ca), Q$			
	Energy	Apparent power	$S_a(ab), S_b(bc), S_c(ca), S$	kVA	1kVA – 99,999kVA	±2%
		Active energy	$WH_a(ab), WH_b(bc),$ $WH_c(ca), WH$	kWh MWh	1kWh – 9999.99MWh	±2%
		Reactive energy	$VARH_a(ab), VARH_b(bc),$ $VARH_c(ca), VARH$	kVarh Mvarh	1kVarh – 9999.99MVarh	±2%
Req.	Reverse active energy	$rWH_a(ab), rWH_b(bc),$ $rWH_c(ca), rWH$	kWh MWh	1kWh – 9999.99MWh	±2%	
	Frequency	F	Hz	45 – 65Hz		
Power factor	Power factor (PF)	$PF_a(ab), PF_b(bc), PF_c(ca), PF$		+ Lead, - Lag		
Unbalance	Unbalance rate	$I_{unbalance}, V_{unbalance}$	%	0.0 – 100.0		
	Active power demand	Peak demand	kW	1kW – 99,999kW		
Demand	Current demand	1st – 63th harmonics of $V_a(ab),$ $V_b(bc), V_c(ca)$	A	80A – 65,535A		
	Voltage harmonics	1st – 63th harmonics of I_a, I_b, I_c	V	60 – 690V		
S type	Harmonics	Current harmonics		A	80A – 65,535A	
		THD, TDD		%	0.0 – 100.0	
		K-Factor		-	0.0 – 100.0	



Voltage module

For P and S type relay, separate voltage module is provided to measure other element besides current

- Voltage input range: AC 60 – 690V

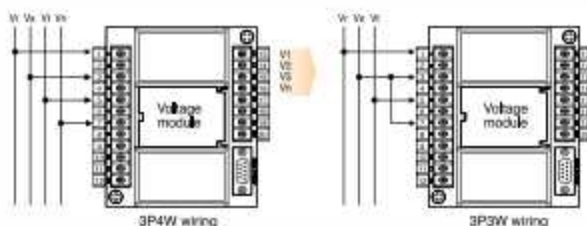

Man machine interface

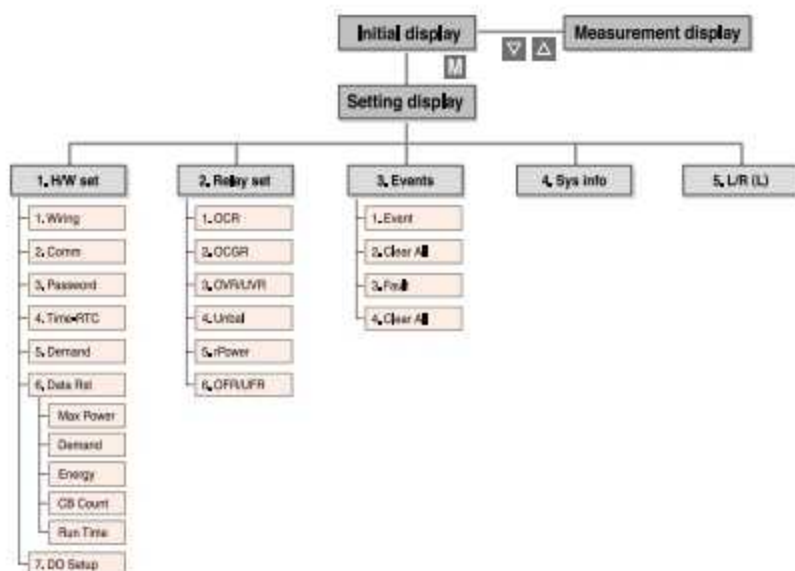

An example of graphic LCD display

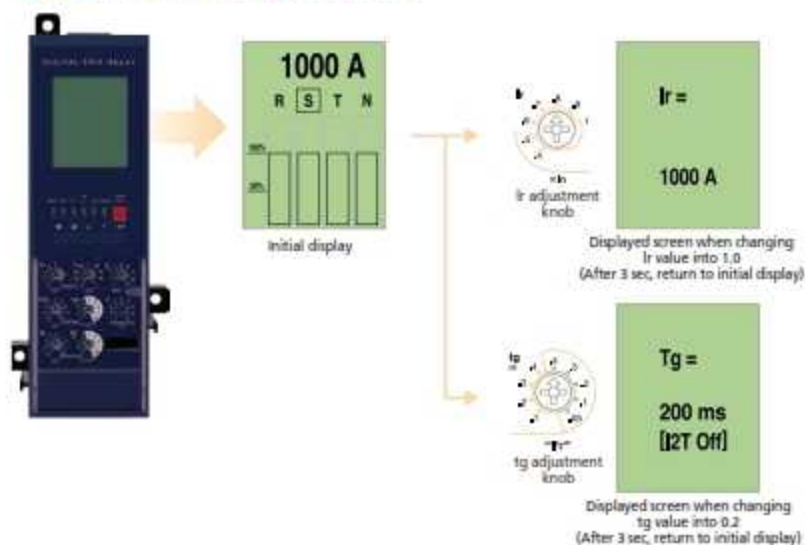

Trip relays

Protection element setting

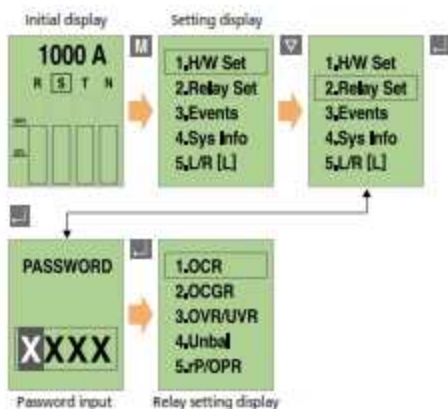

Find adjustment of protection setting current

- OCR and OCGR's current setting is basically controlled by knob's setting values.
- The fine current that cannot be controlled by knob is adjustable by using **ENT** key.
- Fine adjustment is only adjustable in the present knob and next knob's setting range, when moving knob, the adjusted data becomes reset state.

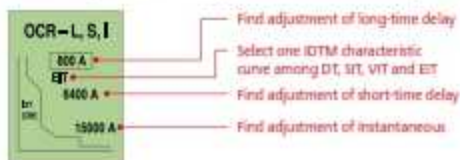

- The setting method of OCGR is same with OCR's fine adjustment is available.

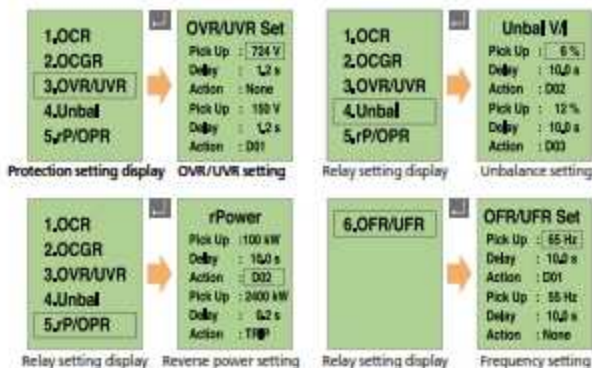
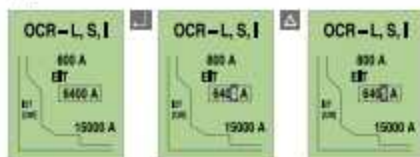

Measurement element display

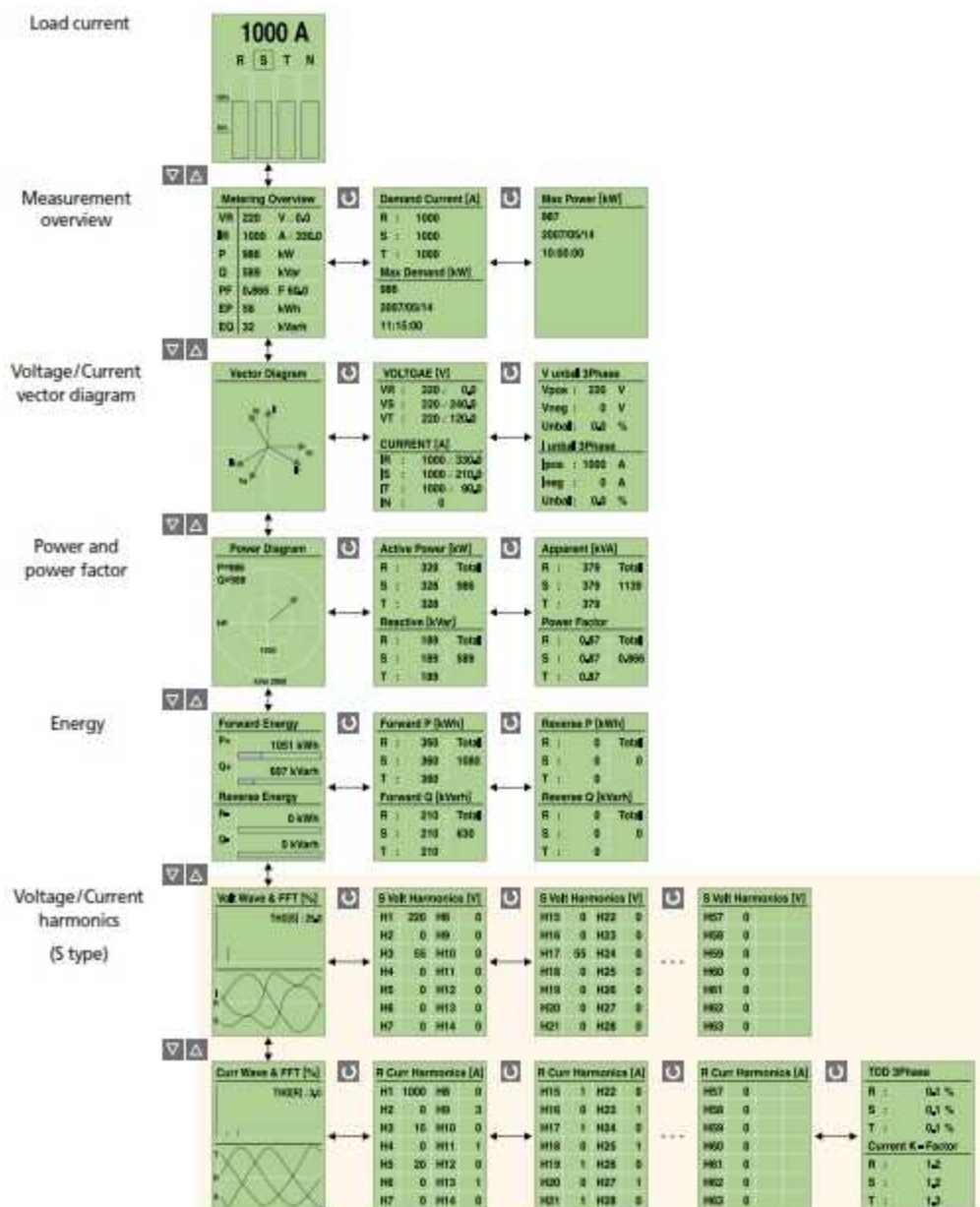

Trip relays

Characteristic curves

Long-time delay (L)

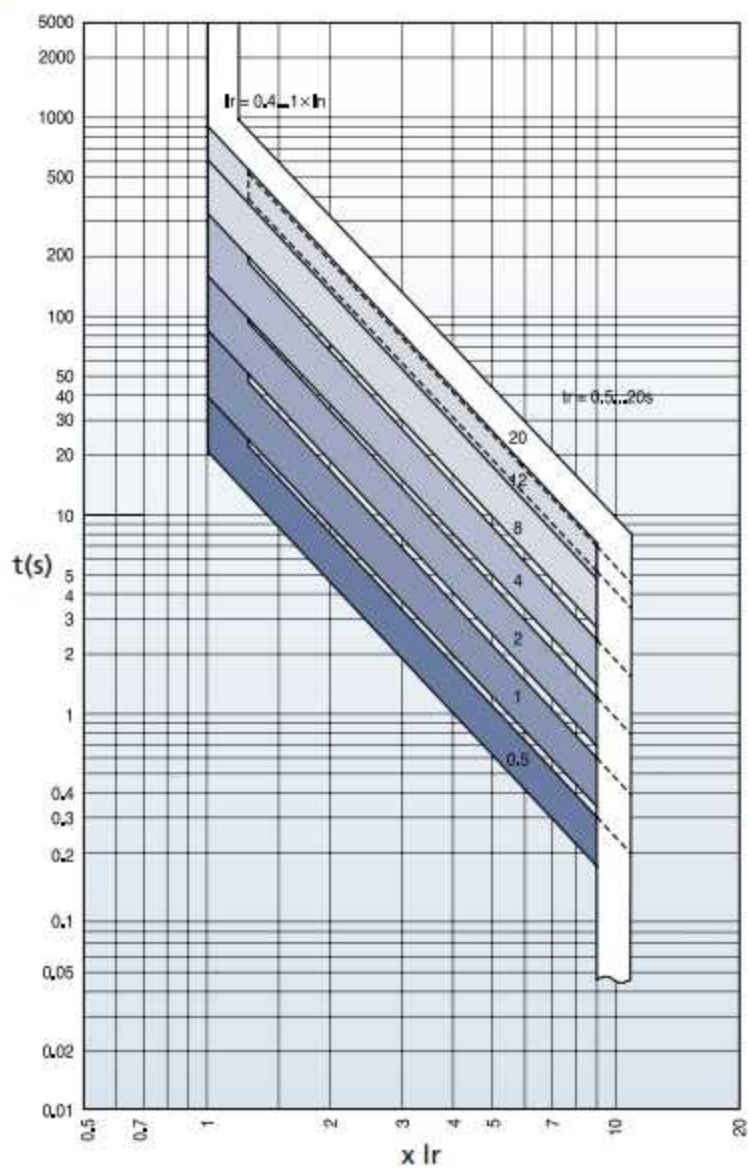

Short-time delay (s)

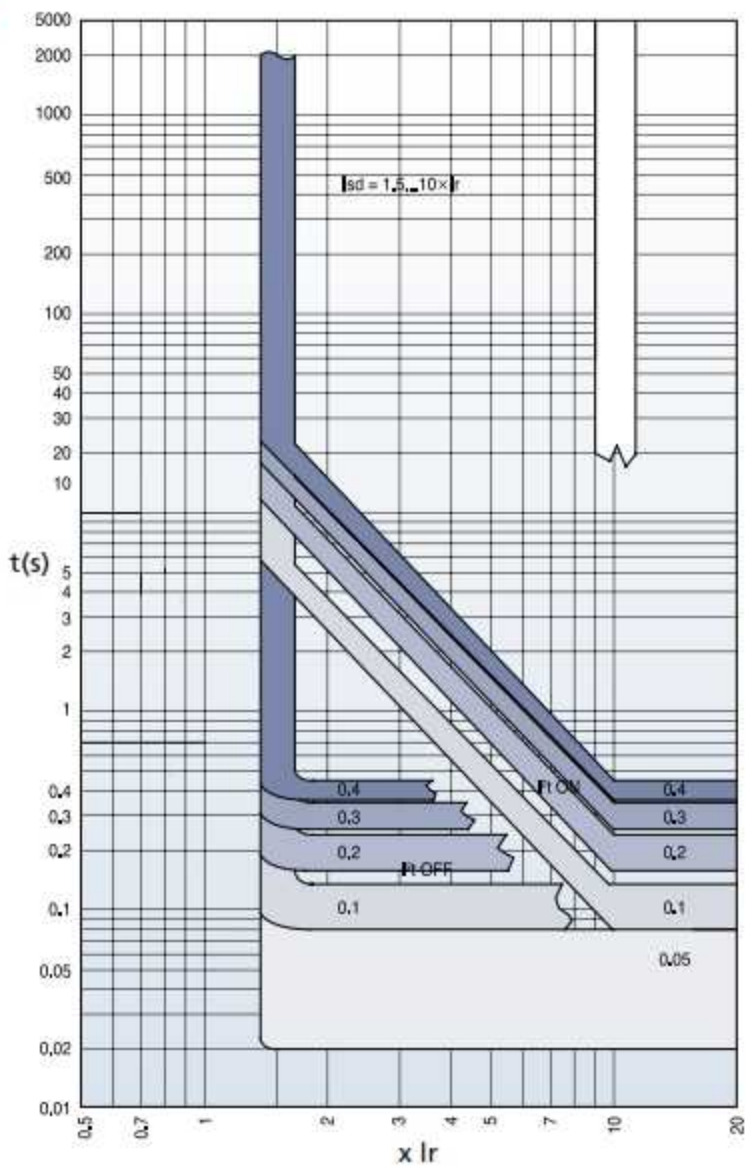

Trip relays

Characteristic curves

Instantaneous (I)
Ground fault (G)

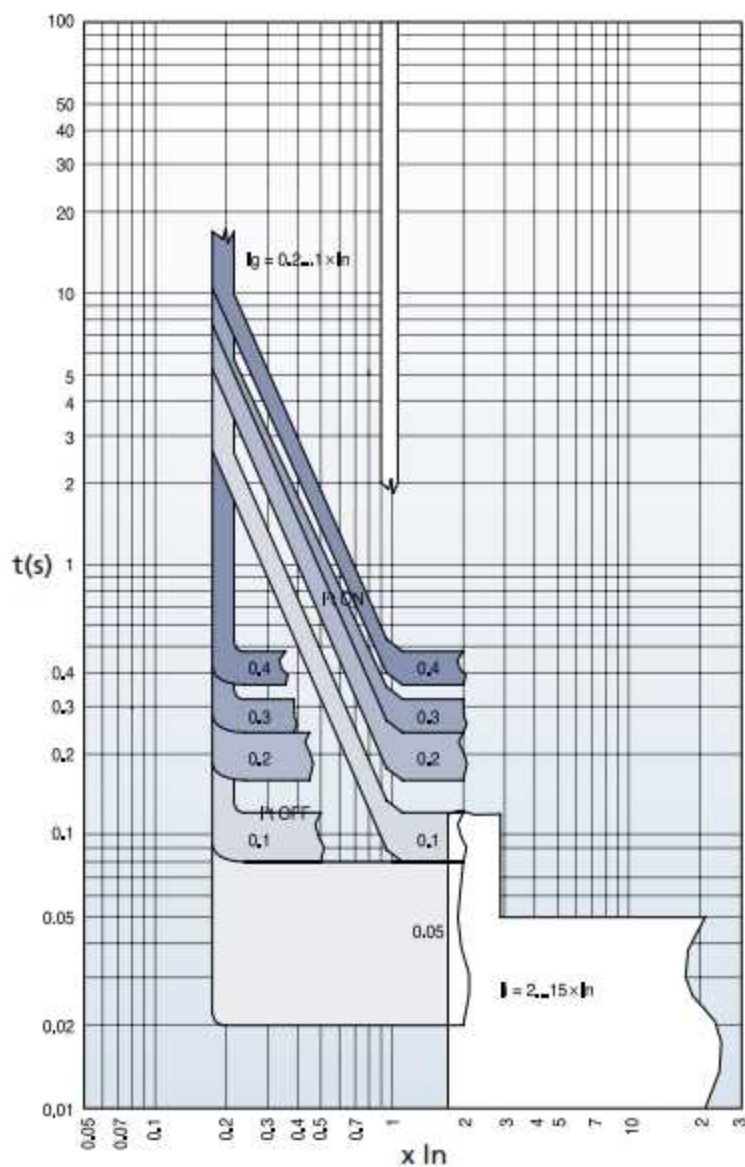

IDMTL

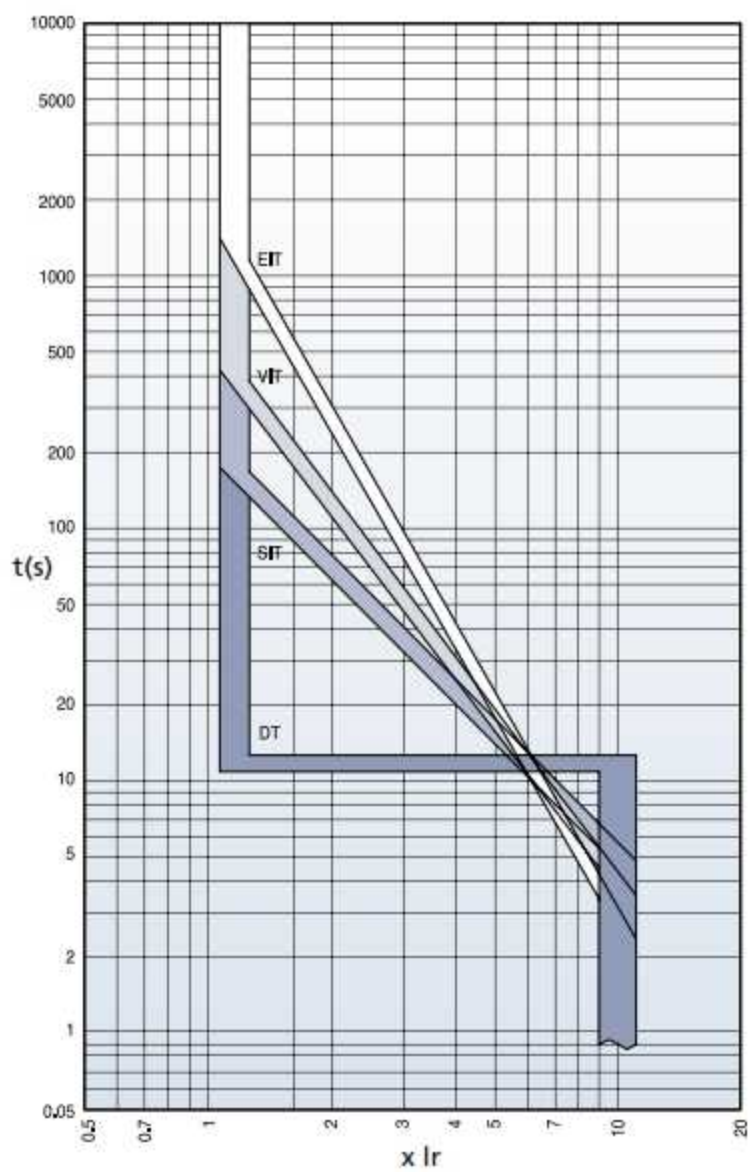

Trip relays

Characteristic curves

Pre Trip Alarm

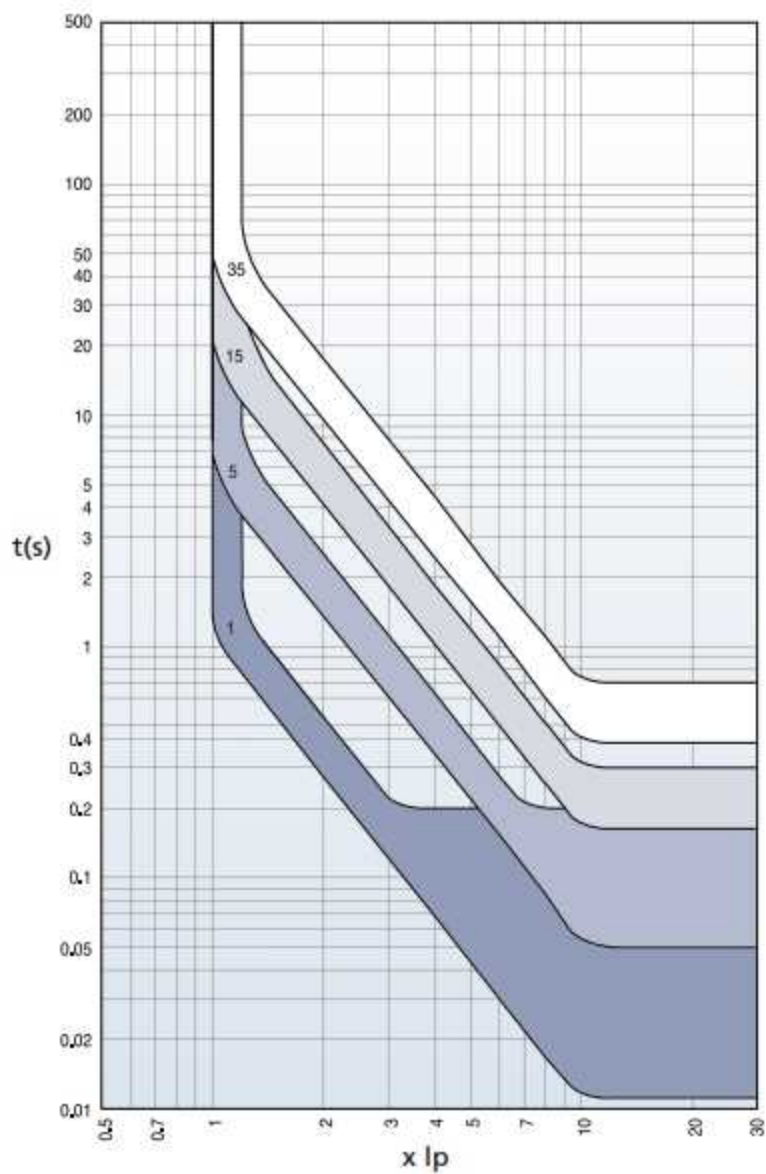

ZSI - Zone Selective Interlocking (A, P, S type)

Zone-selective interlocking drops delay time that eliminates faults for breakers. It minimizes the shock that all kinds of electric machineries get under fault conditions.

1. In case of that short time-delay or ground fault accident occurs at ZSI built in system, the breaker at accident site sends ZSI signal to halt upstream breaker's operation.
2. To eliminate a breakdown, trip relay of ACB at accident site activates trip operation without time delay.
3. The upstream breaker that received ZSI signal adhere to pre-set short time-delay or ground fault time-delay for protective coordination in the system. However upstream breaker that did not receive its signal will trip instantaneously.
4. For ordinary ZSI operation, it should arrange operation time accordingly so that downstream circuit breakers will react before upstream ones under overcurrent/short time delay/ground fault situations.
5. ZSI connecting line needs to be Max. 3m.

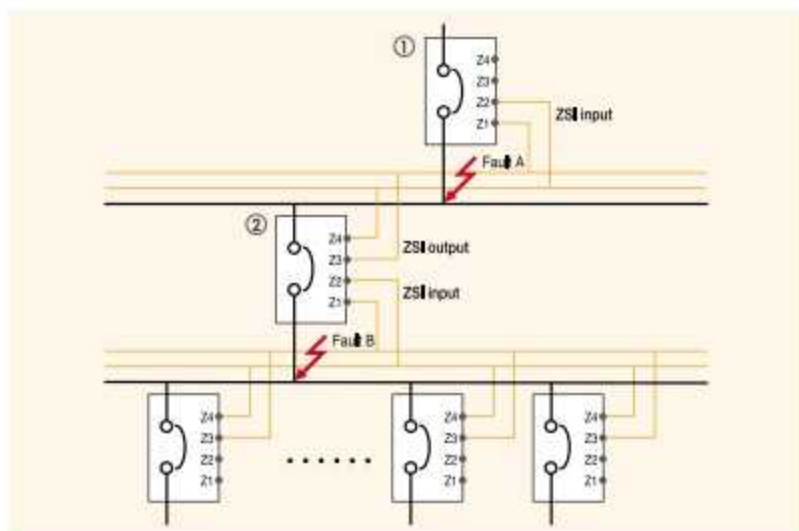

- 1) Occurrence of fault A
 - Only breaker ① performs instantaneous trip operation.
- 2) Occurrence of fault B
 - Breaker ② performs instantaneous trip operation, breaker ① performs trip operation after prearranged delay time
 - But if breaker ② did not break the fault normally, breaker ① performs instantaneous trip operation to protect system.

Trip relays

Remote reset and digital I/O (A, P, S type)

In case of that ACB operates due to accidents or over current, Trip relay indicates the information of the accident through the LED and LCD. Trip relay A, P and S type is possible to perform the remote reset by digital input, and have 3 DO (Digital output).

1. Methods to reset Trip relay is to push the Reset button on the frontal side and to use the remote reset.
 2. Digital input
 - [R11-R22] input: Remote reset
 - [Z1-Z2] input: ZSI input
 - [E1-E2] input: ZCT for earth leakage detection or external CT input
- *All DI are dry contact that has 3.3V of recognition voltage. When inputting close by SSR (Solid State Relay) or open-collector, connect collector (Drain) to R11.
3. Digital output 3a (524, 534, 544-513)
 - Fault output: Long/Short time delay, Instantaneous, Ground fault, UVR, OVR, UFR, OFR, rPower, Vunbal, lunbal (Maintains state as Latch from until user pushes reset.)
 - General DO: when setting L/R as remote, it is available to control close/open remotely by using communication.

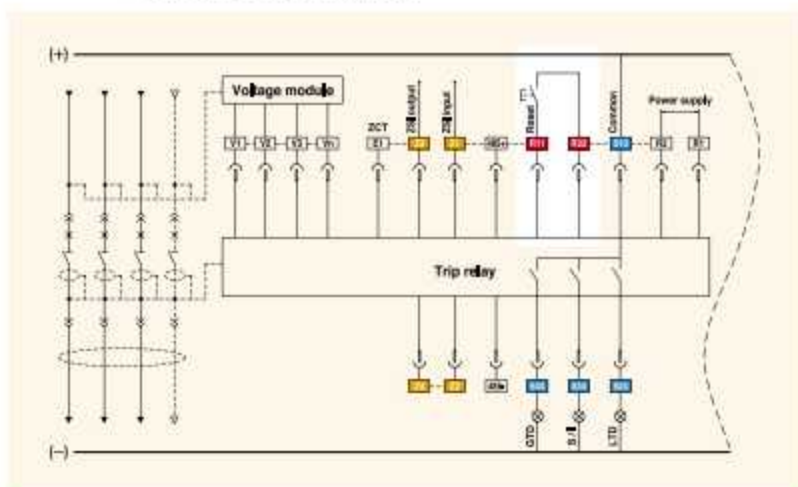

Trip Relay	Digital Output	Long time	Short time	Instantaneous	Ground	Overload Alarm	OVR	UVR	rPower	Vunbal	lunbal	OFR	UFR	OFR	Note
P, S type	DO1 (524)	●	○	○	○	○	○	○	○	○	○	○	○	○	Programmable
	DO2 (534)	○	●	●	○	○	○	○	○	○	○	○	○		
	DO3 (544)	○	○	○	○	●	○	○	○	○	○	○	○		
A type	DO1 (524)	●	x	x	x	Not available	Not available	Not available	Not available	Not available	Not available	Not available	Not available	Not available	Fixed
	DO2 (534)	x	●	●	x										
	DO3 (544)	x	x	x	●										

Communication

Modbus / RS-485

- Operation mode: Differential
- Distance: Max. 1.2km
- Cable: General RS-485 shielded twist 2-pair cable
- Baud rate: 9,600bps, 19,200bps, 38,400bps
- Transmission method: Half-Duplex
- Termination: 150Ω

Profibus - DP

- Profibus-DP module is installed separately (Option)
- Operation mode: Differential
- Distance: Max. 1.2km
- Cable: Profibus-DP shielded twist 2-pair cable
- Baud rate: 9,600bps – 12Mbps
- Transmission method: Half-Duplex
- Termination: 150Ω
- Standard: EN 50170/DIN 19245



Profibus-DP
Communication module
(Option)

Trip relays

Event & fault recording (P,S type)

When there are events such as setting change, Info. change, error of self-diagnose, state change, P and S type record Max. up to 256 information of the events in accordance with time (ms). In addition, they can record Max. up to 256 (up to 10 for A type) information of the faults such as fault cause, fault phase, fault value and so on in accordance with time (ms).

Event information display

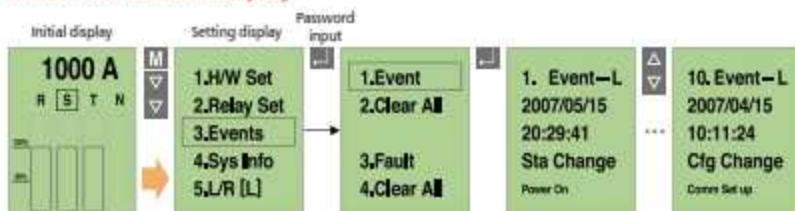

Fault information display

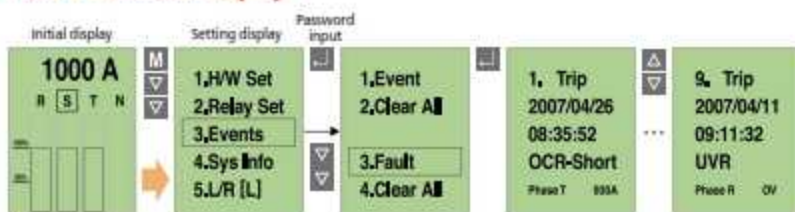

System information

P and S type can indicate information as followings with the information of the ACB.

- Present time: year/month/date/hour/minute/ms
- ACB current ratings
- N-phase current ratings: 100%
- Frequency information: 60Hz/50Hz
- Closing numbers of breaker: CB ON numbers
- Trip relay operating time: OCR ON time
- On time of breaker: CB ON time
- S/W ver. information

System information display

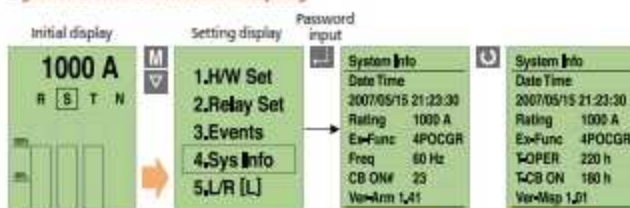

System block diagram

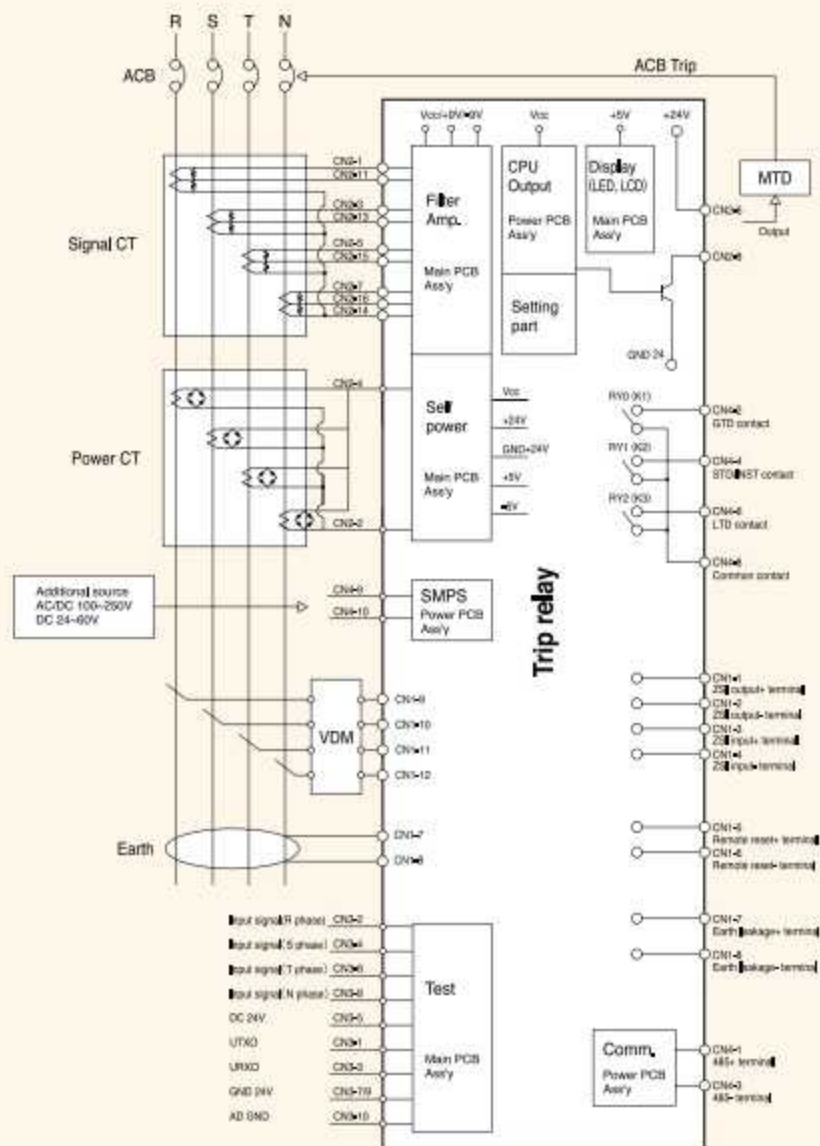

Accessories



Mounting	Accessories		AH		AS		AN		Remark	Page	
			Default	Option	Default	Option	Default	Option			
Internal	SHT1	Shunt Coil	●		●		●		*	50	
	SHT2	Double Shunt Coil		○		○		○	*	51	
	CC	Closing Coil	●		●		●		*	52	
	M	Motor	●		●		●		*	53	
	CS1	Charge Switch	●		●		●		*	53	
	CS2	Charge Switch Communication		○		○		○	*	53	
	UVT	Under Voltage Trip Device		○		○		○	*	54	
	AL	Trip Alarm Contact		○		○		○	*	55	
	MRB	Manual Reset Button		○		○		○	*	56	
	RES	Remote Reset Switch		○		○		○	*	57	
	RCS	Ready to Close Switch		○		○		○	*	58	
	C	Counter	●			○		○	*	58	
	AX	Auxiliary Switch		○		○		○	*	59	
	TM	Temperature Alarm		○		○		○	*	70	
	External	K1	Key Lock		○		○		○	*	60
		K2	Key Interlock Set		○		○		○	*	60
K3		Double Key Lock		○		○		○	*	61	
B		On / Off Button Lock		○		○		○	*	61	
LH		Lifting Hook		○		○		○		62	
CTD		Condenser Trip Device		○		○		○		62	
ATS		Automatic Transfer Switch Controller		○		○		○		63	
DC		Dust Cover		○		○		○		65	
OT		OCR Tester		○		○		○		64	
∩		Manual Connector		○	●		●		*		
A	Automatic Connector	●			○		○	*			

*Separate purchasing is not allowed. Each item should be purchased with the main body.



Mounting	Accessories		AH		AS		AN		Remark	Page
			Default	Option	Default	Option	Default	Option		
Trip relay	N	N type		<input type="radio"/>		<input type="radio"/>		<input type="radio"/>	*	24
	A	A type		<input type="radio"/>		<input type="radio"/>		<input type="radio"/>	*	26
	P	P type		<input type="radio"/>		<input type="radio"/>		<input type="radio"/>	*	28
	S	S type		<input type="radio"/>		<input type="radio"/>		<input type="radio"/>	*	30
	ZCT	ZCT for the earth leakage		<input type="radio"/>		<input type="radio"/>		<input type="radio"/>		
Cradle	SBC	Shorting "b" Contact		<input type="radio"/>		<input type="radio"/>		<input type="radio"/>		65
	MI	Mechanical Interlock		<input type="radio"/>		<input type="radio"/>		<input type="radio"/>		67
	ST	Safety Shutter		<input type="radio"/>		<input type="radio"/>		<input type="radio"/>	*	68
	STL	Safety Shutter Lock		<input type="radio"/>		<input type="radio"/>		<input type="radio"/>		68
	DF	Door Frame		<input type="radio"/>		<input type="radio"/>		<input type="radio"/>		69
	MIP	Mis Insertion Prevent Device		<input type="radio"/>		<input type="radio"/>		<input type="radio"/>		74
	MOC	Mechanical Operated Cell switch		<input type="radio"/>		<input type="radio"/>		<input type="radio"/>		67
	CEL	Cell Switch		<input type="radio"/>		<input type="radio"/>		<input type="radio"/>		70
	DI	Door Interlock		<input type="radio"/>		<input type="radio"/>		<input type="radio"/>		71
	ZAS	Zero Arc Space	●			<input type="radio"/>			*	71
	SC	Safety Control Cover	●		●		●	①	*	72
	CMB	Cradle Mounting Block		<input type="radio"/>		<input type="radio"/>		<input type="radio"/>	*	72
	RI	Racking Interlock		<input type="radio"/>		<input type="radio"/>		<input type="radio"/>		73
	PL	Pad lock / Position Lock	●		●		●		*	73
	IB	Insulation Barrier	●			<input type="radio"/>		<input type="radio"/>	*	69
	UDC	UVT Time Delay Controller		<input type="radio"/>		<input type="radio"/>		<input type="radio"/>		75
ADP	Compatible Adapter		<input type="radio"/>		<input type="radio"/>		<input type="radio"/>			
Other	RPH	Reverse Phase ACB		<input type="radio"/>		<input type="radio"/>		<input type="radio"/>		
	DUM	Dummy ACB		<input type="radio"/>		<input type="radio"/>		<input type="radio"/>		
	VAD	Various Connection Type		<input type="radio"/>		<input type="radio"/>		<input type="radio"/>		
	RCO	Remote I/O		<input type="radio"/>	●		●			77
	PC	Profibus-DP comm. module	●			<input type="radio"/>		<input type="radio"/>		

*Separate purchasing is not allowed. Each item should be purchased with the main body.

① It is available only when the control switch is in the mode of auto connection.

Accessories

Shunt Coil [SHT1]

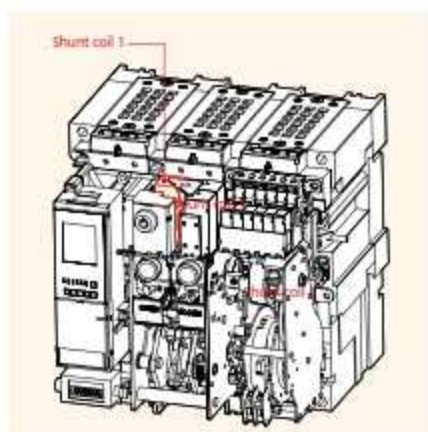

- SHT1 is a control device which trips a circuit breaker from remote place, when applying voltage continuously or instantaneously over 200ms to coil terminals (C1, C2).
- When UVT coil is installed, its location is changed.

1. Rated voltage and characteristics of Trip coil

Rated voltage [Vn]		Operating voltage range [V]	Power consumption [VA or W]		Trip time [ms]
DC [V]	AC [V]		Inrush	Steady-state	
24 - 30	-	0.6 - 1.1 Vn	200	5	Less than 40ms
48 - 60	48	0.6 - 1.1 Vn			
100 - 130	100 - 130	0.56 - 1.1 Vn			
200 - 250	200 - 250	0.56 - 1.1 Vn			
-	380 - 480	0.56 - 1.1 Vn			

Note: Operating voltage range is the max. rated voltage standard for each rated voltage [Vn].

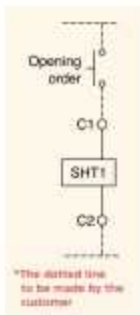

*The dotted line to be made by the customer

Wiring Diagram

2. Specification of the wire

- Refer to the below table regarding the length and specification of wire when using trip coil with DC 24 - 30 [V] or DC/AC 48 - 60 [V] of rated voltage.

The maximum wire length

		Rated voltage [Vn]			
		DC 24 - 30 [V]		DC/AC 48 [V]	
Wire type		#14 AWG (2.08mm ²)	#16 AWG (1.31mm ²)	#14 AWG (2.08mm ²)	#16 AWG (1.31mm ²)
Operating voltage	100%	95.7m	61m	457.8m	287.7m
	85%	62.5m	38.4m	291.7m	183.2m

Double Shunt Coil [SHT2]

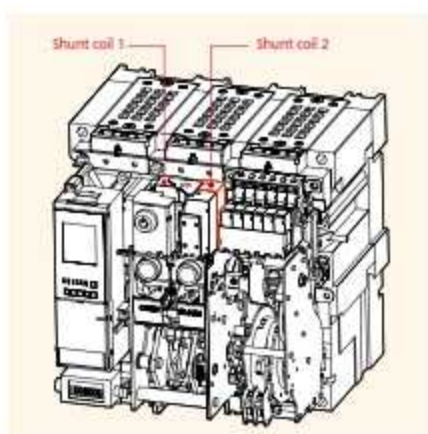

- SHT2 is a control device which trips a circuit breaker doubly from the outside. When SHT1 doesn't operate normally, it can trip a circuit breaker safely.
- Shunt coil 1: Install it at existing location.
- Shunt coil 2: Install it on the right side of the Shunt coil 1
- It is not available with UVT coil when installing couple shunt coil.

1. Rated voltage and characteristics of Trip coil

Rated voltage [Vn]		Operating voltage range [V]	Power consumption (VA or W)		Trip time [ms]
DC [V]	AC [V]		Inrush	Steady-state	
24 - 30	-	0.6 - 1.1 Vn	200	5	Less than 40ms
48 - 60	48	0.6 - 1.1 Vn			
100 - 130	100 - 130	0.56 - 1.1 Vn			
200 - 250	200 - 250	0.56 - 1.1 Vn			
-	380 - 480	0.56 - 1.1 Vn			

Note: Operating voltage range is the max. rated voltage standard for each rated voltage [Vn].

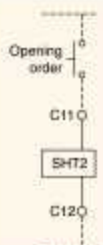

*The dotted line to be made by the customer

Wiring Diagram

2. Specification of the wire

- Refer to the below table regarding the length and specification of wire when using trip coil with DC 24 - 30 [V] or DC/AC 48 - 60 [V] of rated voltage.

The maximum wire length

		Rated voltage [Vn]			
		DC 24 - 30 [V]		DC/AC 48 [V]	
Wire type		#14 AWG (2.08mm ²)	#16 AWG (1.31mm ²)	#14 AWG (2.08mm ²)	#16 AWG (1.31mm ²)
Operating voltage	100%	95.7m	61m	457.8m	287.7m
	85%	62.5m	38.4m	291.7m	183.2m

Accessories

Closing Coil [CC]

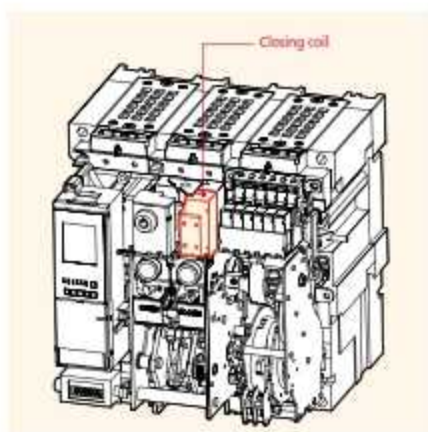

- It is a control device which close a circuit breaker, when the voltage is applied continuously or instantaneously over 200ms to the coil terminals (C1, C2).

1. Rated voltage and characteristics of Closing coil

Rated voltage [Vn]		Operating voltage range [V]	Power consumption (VA or W)		Trip time [ms]
DC [V]	AC [V]		Inrush	Steady-state	
24 - 30	-	0.75 - 1.1 Vn	200	5	Less than 80ms
48 - 60	48	0.75 - 1.1 Vn			
100 - 130	100 - 130	0.75 - 1.1 Vn			
200 - 250	200 - 250	0.75 - 1.1 Vn			
-	380 - 480	0.75 - 1.1 Vn			

Note: Operating voltage range is the max. rated voltage standard for each rated voltage [Vn].

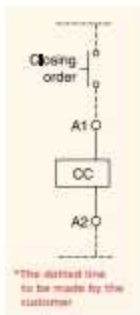

Wiring Diagram

2. Specification of the wire

- Refer to the below table regarding the length and specification of wire when using trip coil with DC 24 - 30 [V] or DC/AC 48 - 60 [V] of rated voltage.

The maximum wire length

		Rated voltage [Vn]			
		DC 24 - 30 [V]		DC/AC 48 [V]	
Wire type		#14 AWG (2.08mm ²)	#16 AWG (1.31mm ²)	#14 AWG (2.08mm ²)	#16 AWG (1.31mm ²)
Operating voltage	100%	95.7m	61m	457.8m	287.7m
	85%	62.5m	38.4m	291.7m	183.2m

Motor [M]

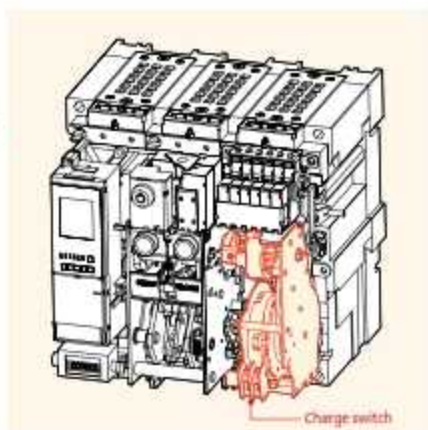

- Charge the closing spring of a circuit breaker by the external power source. Without the external power source, charge manually.
- Operating voltage range (IEC 60947) 85% – 110%Vn

Input voltage (V)	DC 24 – 30V	AC/DC 48 – 60V	AC/DC 100 – 130V	AC/DC 200 – 250V	AC 380V	AC440 – 480V
Load current (max.)	5A	3A	1A	0.5A	0.3A	0.3A
Starting current (max.)	5 times of load current					
Load rpm (Motor)	15,000 – 19,000 rpm					
Charge time	Less than 5 sec.					
Dielectric strength	2kV/min					
Using temperature range	-20° – 60°					
Using humidity range	Max. RH 80% (No dew condensation)					
Endurance	15,000 cycle (Load connection, 2 times/min)					
Charge switch	10A at 250VAC					

Charge Switch [CS1]

Charge Switch Communication [CS2]

- It is a built-in contact which sends the signal to the outside, when motor charging is completed, (2a)
- It has a "1a" contact for communication and the other "1a" contact for complete charging.
- When using an extra communication module (Reote I/O), the state of contacts can be displayed through the network.
- 10A at 250VAC

*Charge Switch Communication [CS2] is applicable only at R23 type

Accessories

Under Voltage Trip device [UVT]

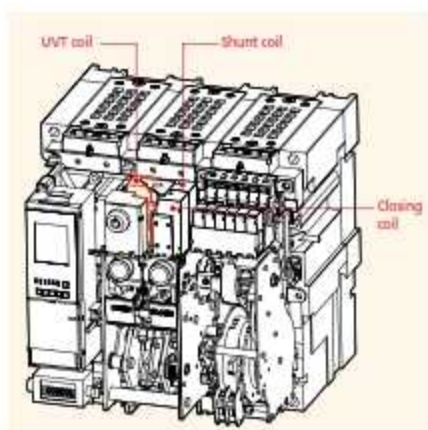

- If the voltage of the main or the control power is under voltage, UVT which is installed inside of the breaker breaks the circuit automatically. Please connect with UVT time-delay device in order to present the time-delay function because UVT is technically instantaneous type.
- The closing of a circuit breaker is impossible mechanically or electrically if control power not supplied to UVT. To close the circuit breaker, 65 – 85% of rated voltage should be applied to both terminals of UVT coil (D1, D2).
- When using UVT coil, the double trip coil can not be used, and the location of trip coil is changed.

1. Rated voltage and characteristics of UVT coil

Rated voltage [Vn]		Operating voltage range [V]		Power consumption [VA or W]		Trip time [ms]
DC [V]	AC [V]	Pick up	Drop out	Inrush	Steady-state	
24 – 30	-	0.65 – 0.85 Vn	0.4 – 0.6 Vn	200	5	Less than 50ms
48 – 60	48					
100 – 130	100 – 130					
200 – 250	200 – 250					
-	380 – 480					

Note: Operating voltage range is the min. rated voltage standard for each rated voltage [Vn].

2. Specification of the wire

- Refer to the below table regarding the length and specification of wire when using trip coil with DC 24 – 30 [V] or DC/AC 48 – 60 [V] of rated voltage.

The maximum wire length

		Rated voltage [Vn]			
		DC 24 – 30 [V]		DC/AC 48 [V]	
Operating voltage	Wire type	#14 AWG (2.08mm ²)	#16 AWG (1.31mm ²)	#14 AWG (2.08mm ²)	#16 AWG (1.31mm ²)
		100%	48.5m	30.5m	233.2m
	85%	13.4m	8.8m	62.2m	39.3m

Note: In case of using UVT coil, the location of TC coil is changed.

Trip Alarm Contact [AL]

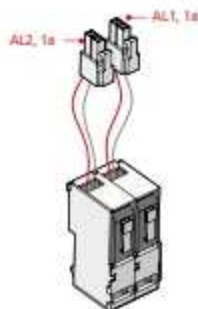

- When a circuit breaker is tripped by OCR which operates against the faulty current (Over Current Relay), Trip Alarm switch provides the information regarding the trip of circuit breaker by sending the electrical signal from the mechanical indicator on main cover of main circuit breaker or internal auxiliary switch. (Installed at the inside of circuit breaker)
- When a circuit breaker tripped by faulty current, a mechanical trip indicator (MRB, Manual Reset Button) pops out fro the main cover and the switch (AL) which sends control signal electrically is conducted to output the information occurred from faulty circuit breaker.
- MRB and AL can be operated only when tripping by OCR, but doesn't be operated by Off button and OFF operation of trip coil.
- To re-close a circuit breaker after a trip, press MRB to reset it for closing.
- 2 pcs of electrical trip switch (AL1, AL2, 1a) are provided (Option)
- Trip alarm contact and MRB (Manual reset button) need to be purchased together.

1. Electrical characteristics of trip alarm contact

Rated voltage (V)	Non-inductive load (A)		Inductive load (A)		Inrush current
	Resistive load	Lamp load	Inductive load (A)	Motor load	
8V DC	11	3	6	3	Max. 24A
30V DC	10	3	6	3	
125V DC	0.6	0.1	0.6	0.1	
250V DC	0.3	0.05	0.3	0.05	
250V AC	11	1.5	6	2	

Accessories

Manual Reset Button [MRB]



- It is a function which resets a circuit breaker manually when a circuit breaker is tripped by OCR.
- When a circuit breaker tripped by faulty current, a mechanical trip indicator (MRB, Manual Reset Button) pops out fro the main cover and the switch (SDE) which sends control signal electrically is conducted to output the information occurred from faulty circuit breaker.
- MRB can be operated only by OCT but not by OFF operation of circuit breaker. To re-close a circuit breaker after a trip, press MRB to reset it for closing.

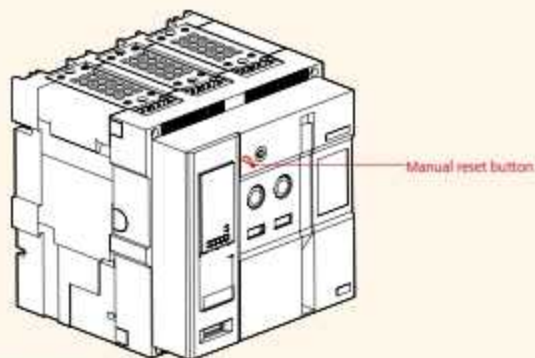
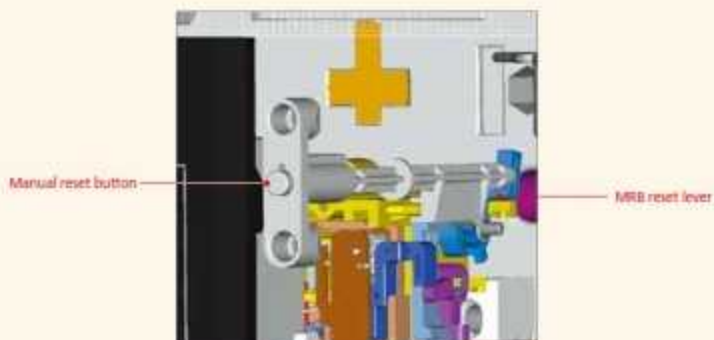

Note: The manual reset button is protected by the front of the

Remote Reset Switch [RES]

- Following tripping, this function resets the "fault trip" alarm contacts (AL) and the mechanical indicator (MRB) and enables circuit breaker closing.
Push button switch: AC 125V 10A, AC 250V 6A, DC 110V 2.2A, DC 220V 1.1A Resistive load
- In case of auto reset type circuit breaker
Following tripping, a reset of Manual Reset Button (MRB) or Remote Reset Switch (RES) is no longer required to enable circuit breaker closing.
The mechanical indicator (MRB) and electrical indicator (AL) remain in fault position until reset button is pressed.
- AL2 and RES are alternative

1. Rated voltage and rated current of RES

Rated voltage	Operating current (Max.)		Operating time	Wire spec.	
	AC	DC			
AC/DC 100 - 130V	6A	3A	Less 40ms	#14 AWG (2.08 mm ²)	
	3A	2.5A			
AC/DC 200 - 250V	3A	2.5A			#16 AWG (1.31mm ²)
	2.5A				



*The dotted line to be made by the customer

Wiring Diagram

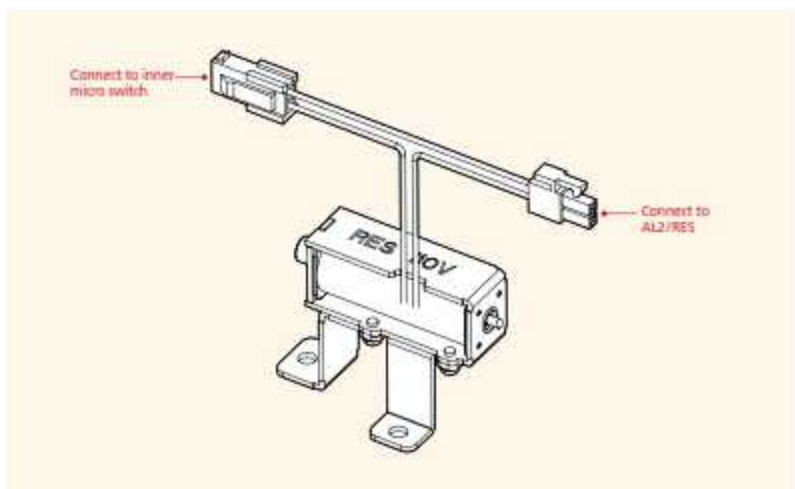

Accessories

Ready to Close Switch [RCS]

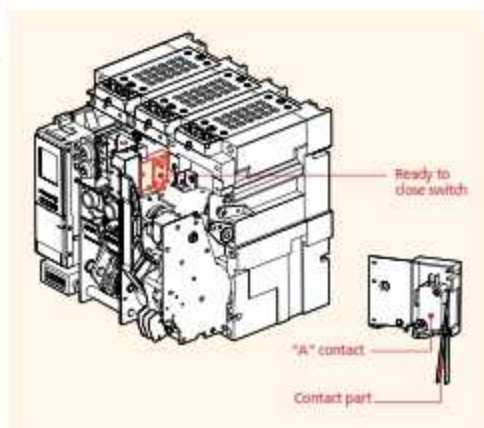

- It interlocks with mechanism of circuit breaker.
- It indicates the status that the circuit breaker is ready to do closing operation.
- When mechanism is in OFF position or in Charge, contact is output with "ON" and it indicates that mechanism can be closed.

Counter [C]

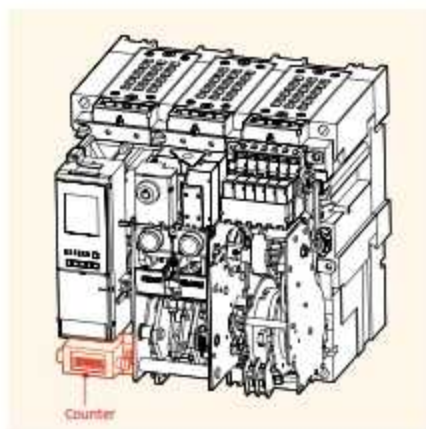

- It displays the total number of ON/OFF operation of ACB.

Auxiliary switch [AX]

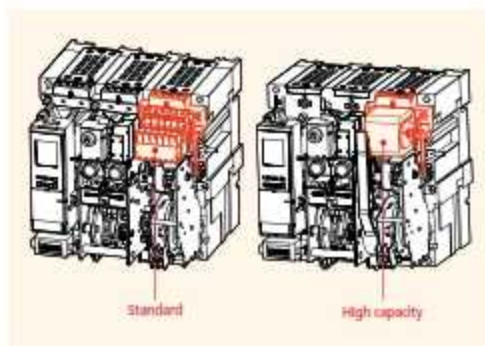
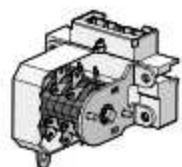
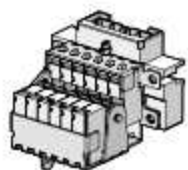

- It is a contact used to monitor ON/OFF position of ACB from remote place.

AUX contact & charging types

AX	Standard OFF charge 3a3b
AC	Standard ON charge 3a3b
BX	Standard OFF charge 5a5b
BC	Standard ON charge 5a5b
HX	High capacity OFF charge 5a5b
HC	High capacity ON charge 5a5b
CC	Standard ON charge 6a6b
JC	High capacity ON charge 6a6b

Standard classification

Standard		High capacity	
2000, 5000AF	4000, 6300AF	2000, 5000AF	4000, 6300AF

Classification		Standard		High capacity		Remark	
		Resistive load	Inductive load	Resistive load	Inductive load		
Contact capacity	AC	490V	5A	6A	5A	2.5A	
		250V	10A	6A	10A	10A	
		125V	10A	6A	10A	10A	
	DC	250V	0.3A	0.3A	3A	1.5A	
		125V	0.5A	0.6A	10A	6A	
30V	10A	6A	10A	10A			
No. of Contact that can be used	AX	3a3b		-		Standard charging type	
	BX	5a5b		-			
	HX	-		5a5b			
	AC	3a3b		-		Rapid auto-reclosing charging type	
	BC	5a5b		-			
	CC	6a6b		-			
	HC	-		5a5b			
JC	-		6a6b				

Accessories

Key Lock [K1]

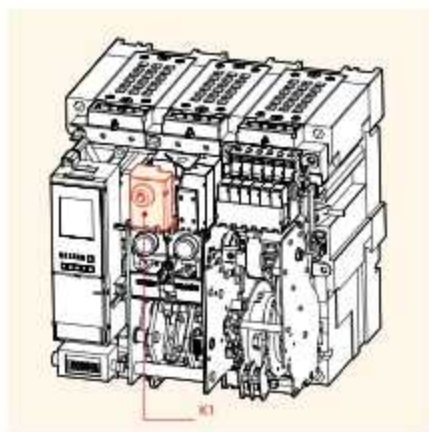

- It is a device for locking which prevents a certain circuit breaker from being operated by user's discretion when two or more circuit breakers are used at the same time.
- K1: Preventing mechanical closing

Key Interlock Set [K2]

Wiring

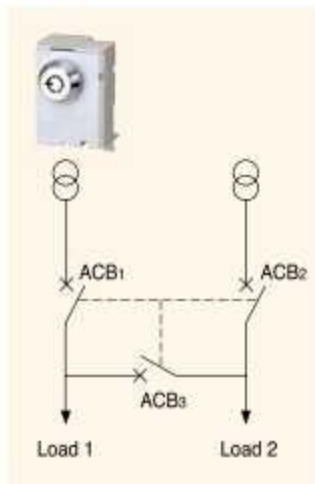

- 3 circuit breakers can be arranged for the continuous power supply to the load side and be interlocked mutually by using Key Lock embedded in each circuit breaker.

ACB-1	ACB-2	ACB-3	Status	
			LOAD1	LOAD2
●	●	●	OFF	OFF
●	○	○	OFF	ON
○	●	○	ON	OFF
○	○	●	ON	ON
●	●	○	OFF	OFF
●	○	●	OFF	ON
○	●	●	ON	OFF

○ Release ● Lock

Double Key Lock [K3]

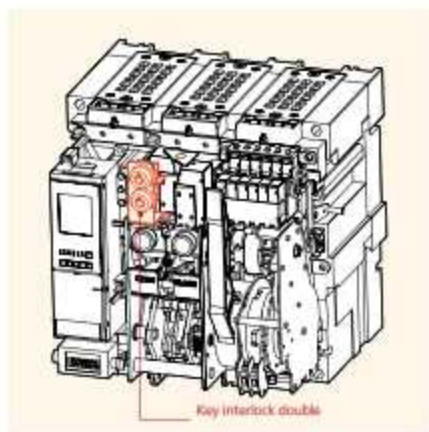

- When only two keys are released at the same time, circuit breakers operate. Handling method is same as K1.

ON/OFF Button Lock [B]



- It is to prevent manual operation of ACB's closing / tripping button due to user's wrong handling.
- It is not possible to handle ON/OFF operation under the "Button lock" status.

Note) Padlocks (25 - 30) are not supported.

Accessories

Lifting Hook [LH]

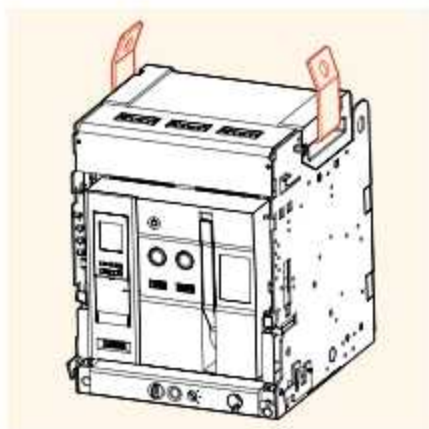

- It is a device to make an ACB easy to shift.
- Please hang it to both handles of the arc cover.

Condenser Trip Device [CTD]

- It gets a circuit breaker tripped electrically with regular time when control power supply is broken down and is used with Shunt coil, SHT. In case there is no DC power, it can be used as the rectifier which supplies DC power to a circuit breaker by rectifying AC power.

Ratings

Ratings	Specification	
Model	CTD-100	CTD-200
Rated input voltage (V)	AC 100/110	AC200/220
Frequency (Hz)	50/60	50/60
Rated charge voltage (V)	140/155	280/310
Charging time	Within 5S	Within 5S
Trip possible time	Over 3 MIN	Over 2 MIN
Range of input voltage (%)	85 - 110	85 - 111
Condenser capacity	400 μ F	100 μ F

External dimension

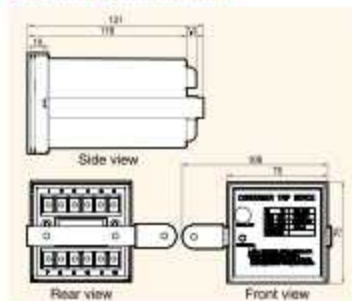

Circuit diagram

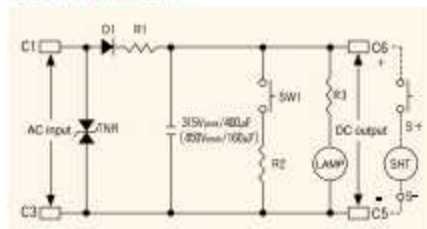

Automatic Transfer Switch Controller [ATS]

Ratings



Model Type	ATSC-11B	ATSC-110-C	ATSC-220	ATSC-220-C
Rated voltage	AC 110V		AC 220V	
Voltage range	AC 98.5 (±5%) – 126.5V (±5%)		AC 187 (±5%) – 253V (±5%)	
Frequency	50Hz / 60Hz			
Power consumption (apparent power)	15.4W			
4-location switch (stop, N, R, Auto)	■	■	■	■
Test function	■	■	■	■
Generator control function	■	■	■	■
NRS function	■	■	■	■
N power source setting (phase-to-phase / 3 phases)	■	■	■	■
Time setting (T1 – T6)	■	■	■	■
Fault function (OCR / Circuit breaker trouble)	■	■	■	■
Output contact (Auto, Load burden)	■	■	■	■
Communication function (RS-485)	-	■	-	■

- T_1 : The delayed time from when UN (power supply or electric company) is tripped to when generator start-up signal contact is closed. (t_1 : 0.1, 0.5, 1, 2, 4, 8, 15, 30, 40, 50secs)
- T_2 : The delayed time from when UN is closed to when ACB_2 is tripped. (t_2 : 0.1, 1, 2, 4, 8, 15, 30, 60, 120, 240secs)
- T_3 : The delayed time from when ACB_1 is tripped to when ACB_2 is closed. (t_3 : 0.5, 1, 2, 5, 10, 15, 20, 25, 30, 40secs)
- T_4 : The delayed time from when ACB_2 is tripped to when ACB_1 is closed. (t_4 : 0.5, 1, 2, 5, 10, 15, 20, 25, 30, 40secs)
- T_5 : The delayed time when ACB_1 is closed to when generator start-up signal contact is opened. (t_5 : 60, 120, 180, 240, 300, 360, 420, 480, 540, 600secs)
- Stop-mode: This mode is for compulsory closing of ACB_1 (electric power company) or ACB_2 (power station) when UN (power supply of electric power company) or UR (power supply of power station) is available
*UN or UR should be kept in ON position
- N-mode: This mode is for compulsory closing of ACB_1 when UN is available.
*it does not matter to be ON or OFF position of UR and if converting to N-mode while using UR, generator start-up signal contact is opened.
- R-mode: This mode is for compulsory closing of ACB_2 during the use of UR regardless of that UN is available or not.
- Auto-mode: This mode is for transferring a circuit breaker automatically to available power supply of UN or UR. In short, it trips the circuit breaker where power supply is not available and it close to the circuit breaker where supply is available.

Accessories

OCR Tester [OT]



• It is a device which can test for the operation of Trip Relay under no power condition.

1. Maximum 17 times rated current can be inputted.
2. It is possible to enter the current value and phase on each of R/S/T/N.
3. Frequency is adjustable.
4. It is available to test for long time delay/short time delay/instantaneous/ground fault.

Configuration



R S T N	R, S, T, N phase signal input
▲ ▼	Increase/Decrease signal input
ESC DEL	Signal setting/Delete
START STOP	Waveform generation/Stop
10% 60% Hz	Select frequency

Dust Cover [DC]

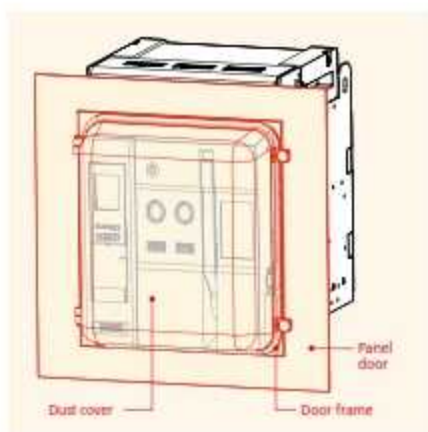

- Attach it to the door frame.
- It protects the product against the dust (IP5X) which may cause faulty operation and enhances the sealing degree by being mounted to protrude type of panel.
- It is transparent so that the front side of ACB is visible and the Cover can be opened/closed even if ACB is drawn out to unit TEST position.

Shorting "b" Contact [SBC]

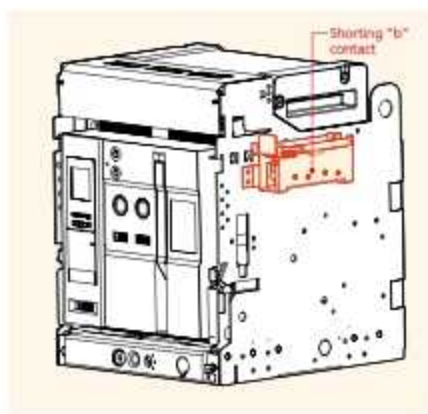
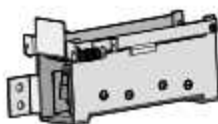

- It is the contact which keeps the external control circuit in normal by Aux. contact which disconnects "Auxb" when ACB is moved from CONNECTED position to TEST position. The number of "shorting b-contact" corresponds to the number of "Auxb" (4b).

Contact condition (Link between Auxb and shorting "b" contact)

ACB location	ACB condition		CLOSE	OPEN
	CONNECTED location	TEST location		
Shorting "b" contact	CONNECTED location	TEST location	OFF	ON
	CONNECTED location	TEST location	OFF	ON

Accessories

Mechanical Operated Cell Switch [MOC]

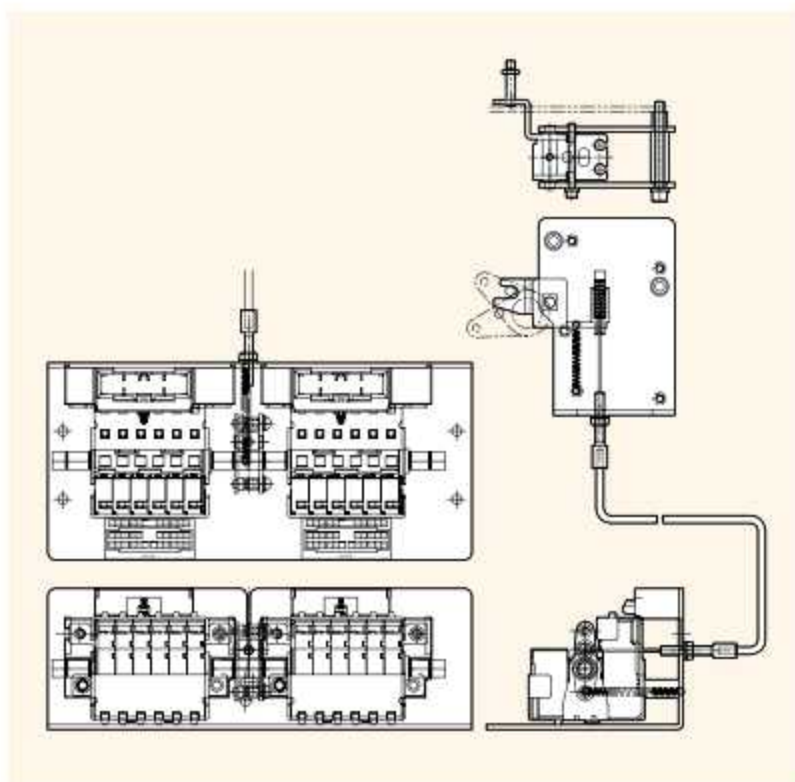

- It is the contact (10a10b) which displays the ON/OFF condition of ACB.
It mechanically operates only when the breaker is "CONNECTED" position.
A standard type and a high capacity type is available.
- The contact capacity is as same as the ratings of aux. contacts.
- When MOC link is installed to cradel, MOC can be equipped with the inside of panel.

Mechanical Interlock [MI]

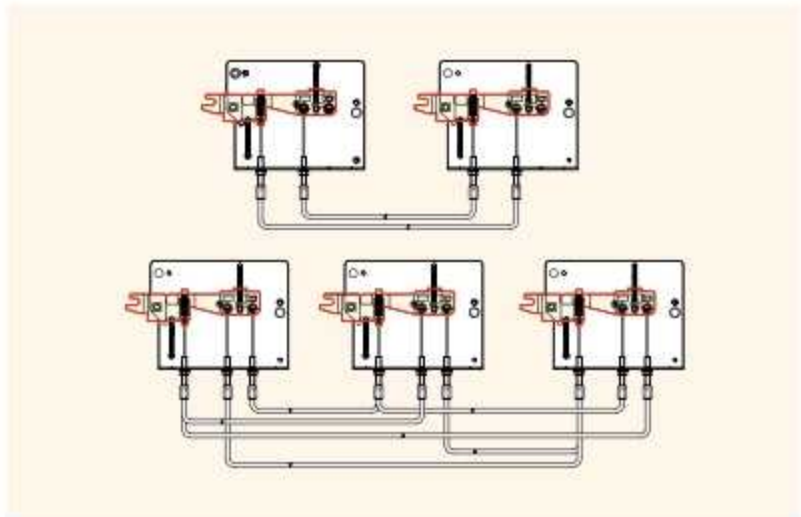

- It is used to interlock closing and trip between two or three breakers mechanically so as to prevent unintended operation at the same time.
- Wire type interlock can be applied upto 3 breakers

Accessories

Safety Shutter [ST]

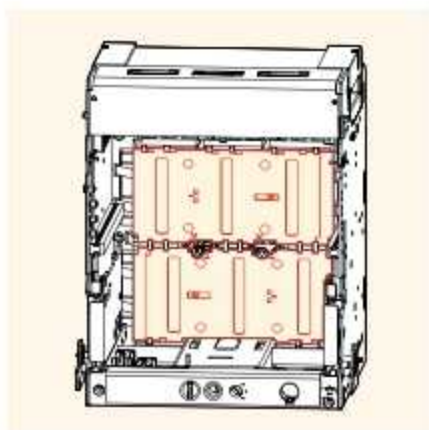

- It is the automatic safety device to protect the connectors of main circuit by cutting off dangerous contact from outside while the breaker is drawn out. When the ACB is drawn in, the shutter is automatically opened.
- There are 4 types of Safety Shutter and they are divided as shown in figure below.

The types of safety shutter plate	
2000/5000AE, 3P	4000/6300AE, 3P
2000/5000AE, 4P	4000/6300AE, 3P

Safety Shutter Lock [STL]

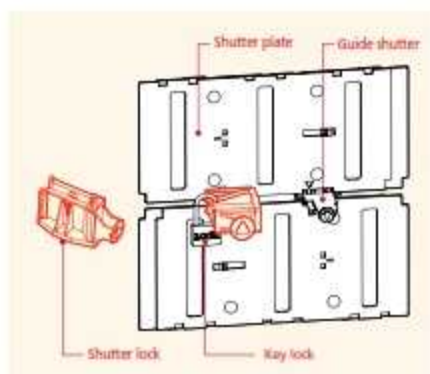

- It is locking device which prevents safety shutter from being opened when it is closed.
- If shutter lock is connected with guide shutter, the guide shutter can not be pushed structurally. Thus, it is not available to open the safety shutter.

Steel Padlocks (20 – 26) are not needed.

Door Frame [DF]

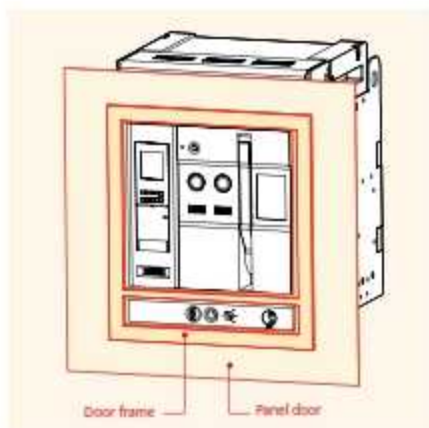

- When structuring the embedded type of ACB panel, it protects the protrude front of ACB and the cutting side of panel door by attaching it to the panel door.

Insulation Barrier [IB]

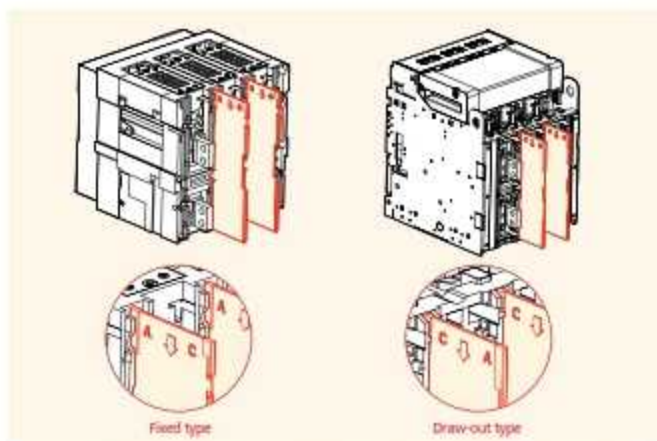

- Insulation barrier prevents the arc which may arise and result in short-circuit between phases in advance
- As "C" stands for "CRADLE", install the insulation barrier in the direction of "C" in case of Draw-out type.
- As "A" stands for "ACB main frame", install the insulation barrier in the direction of "A" in case of Fixed type.

Accessories

Cell Switch [CEL]

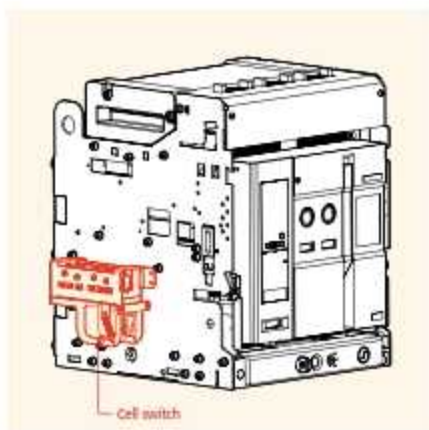

- It is a contact which indicates the present position of ACB.
(CONNECTED, TEST, DISCONNECTED)

<Contact configuration>

4C: 1 Disconnected + 1 Test + 2 Connected

8C: 2 Disconnected + 2 Test + 4 Connected

*Contact configuration can be changed by 3 screws.

ACB position		DISCONNECTED		CONNECTED
Draw-in and draw-out position		DISCONNECTED	TEST	CONNECTED
Contact operation	CL-C (Connected)	OFF		ON
	CL-T (Test)	OFF	ON	
	CL-D (Disconnected)	ON	OFF	
Contact capacity	Voltage (V)		Revised load	Inductive load
	AC	480V	5	2.5
		250V		
		125V	10	10
	DC	250V	3	1.5
		125V	10	10
30V		10	10	
Contact number		4C		

Double Interlock [DI]

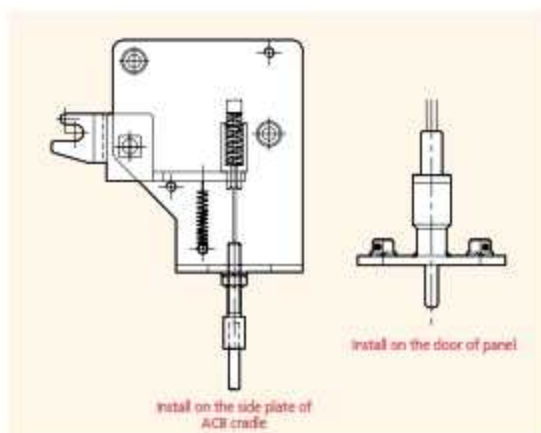

- It is a safety device which does not allow the panel door to open when a circuit breaker is in the "ON" position.

Zero Arc Space [ZAS]



- Arc which may arise while breaking faulty current is extinguished first by Arc chute in main body of circuit breaker and the completely extinguished by Arc cover. By preventing arc from exposing to the outside, it protects itself from all kinds of accidents.
- It is categorized into 8 types by ratings and poles.

Ampere frame	Cover length (mm)
2000AF 3P	281.4
2000AF 4P	366.4
4000AF 3P	359.4
4000AF 4P	474.4
5000AF 3P	576.4
5000AF 4P	746.4
6300AF 3P	732.4
6300AF 4P	962.4

Accessories

Safety Control Cover [SC]



- It protects control terminals which exposes to the outside, and prevents the damages resulted from foreign substances.
- It is categorized into 8 types by ratings and poles.

Ampere frame	Cover length (mm)
2000AF 3P	334
2000AF 4P	419
4000AF 3P	412
4000AF 4P	527
5000AF 3P	629
5000AF 4P	799
8300AF 3P	785
8300AF 4P	1,015

Cradle Mounting Block [CMB]



- It interlocks the main body of circuit breaker and cradle mechanically to fix the former in connected position. Therefore, all draw-in/out are not available.

Racking Interlock [RI]

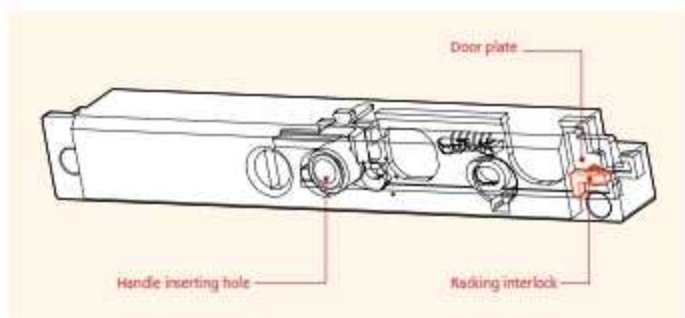

- When panel door is opened, Draw in/out handle doesn't be inserted. Thus, panel handle can be inserted only when panel door is closed.

Pad Lock / Position Lock [PL]

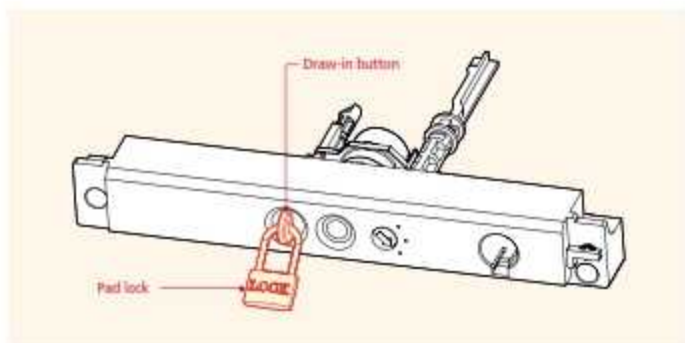

ACB is subject to restriction regarding moving in connected, test, disconnected when drawing in or out. If main body of ACB is placed in 3 positions, it is locked and stopped when drawing in or out.

- As shown in the figure, if draw-in/out button pops out, it means locking is operating.
- To continue Draw-in/out operation, release lock by pushing Draw-in/out button
- In case it is locked as shown in the figure above, main body of ACB can not be drawn in or out into the cradle.
- For the lock device, user has to purchase it. (ø5 – ø6)

Accessories

Miss Insertion Prevent Device [MIP]

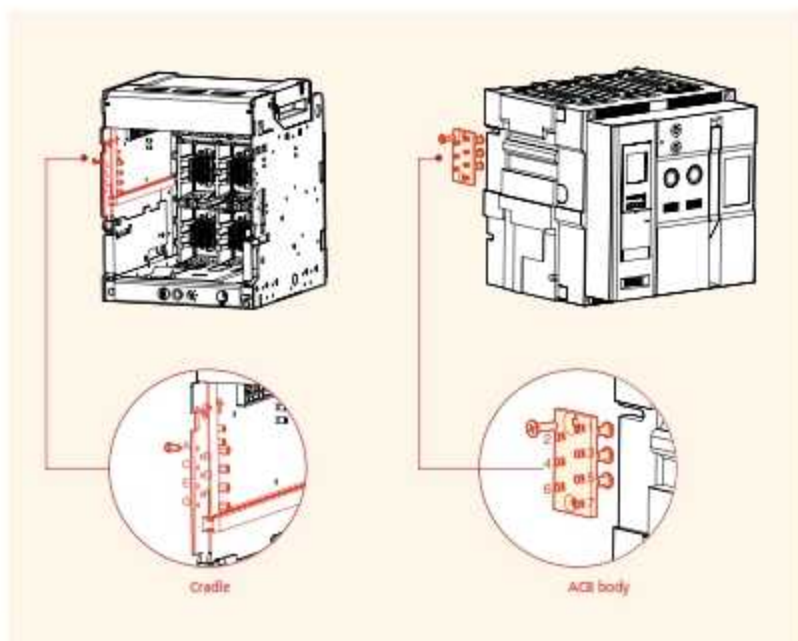

- When the main body of ACB is inserted to the cradle, if the ratings of ACB does not match with cradle, it mechanically prevents ACB from being inserted into cradle of ACB.
- The installation method is variable according to ratings.

Cradle	ACB	Cradle	ACB	Cradle	ACB	Cradle	ACB
ABCD	567	ADEF	237	ABEG	346	BCEG	146
ABCE	467	ADEG	236	ABFG	345	BDEF	137
ABCF	457	ADFG	235	ACDE	267	BDEG	136
ABCG	456	AIEG	234	ACDF	257	BDFG	135
ABDE	367	BCDE	167	ACDG	256	CDEF	127
ABDF	357	BCDF	157	ACEF	247	CDEG	126
ABDG	356	BCDG	156	ACEG	246	CEFG	124
ABEF	347	BCEF	147	ACFG	245	DEFG	123

UVT Time Delay Controller [UDC]

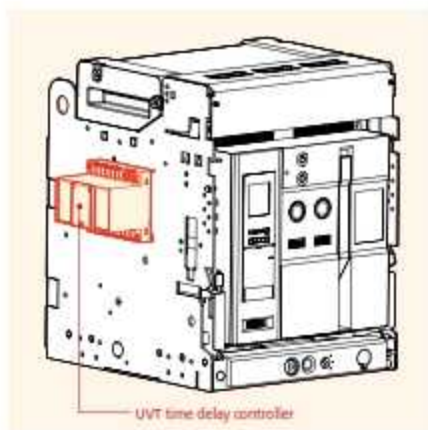

- UVT is a device which makes ACB tripped automatically to prevent the accident on load side due to under voltage or power breakdown. There are two types, Instantaneous type and time delay type.
- It can be installed on the rail or to the cradle.
- Instantaneous type: only available with UVT coil.
- Time delay type: available by connecting UVT coil and UVT time delay controller.
- Common use for the all types.

1. The rated voltage and characteristics of UVT time delay controller

Rated voltage [Vn]		Operating voltage range [V]		Power consumption (VA or W)		Trip time [ms]
DC [V]	AC [V]	Pick up	Drop out	Inrush	Steady-state	
48 - 60	48	0.85 - 0.85 Vn	0.4 - 0.85 Vn	200	5	0.5, 1, 1.5, 3
100 - 130	100 - 130					
200 - 250	200 - 250					
-	380 - 480					

Note: Operating voltage range is the min. rated standard for each rated voltage (Vn).

2. Wiring

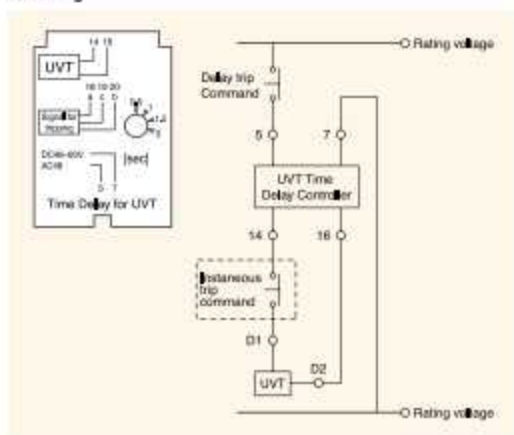

Accessories

Temperature Alarm [TM]

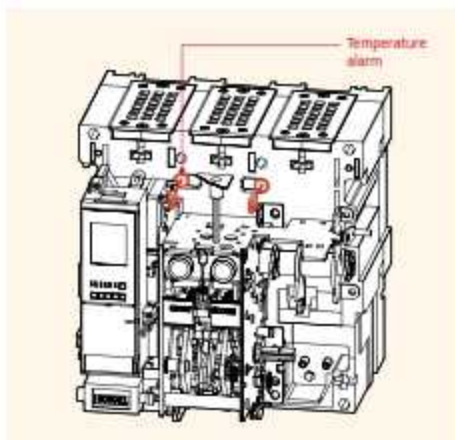

- Temperature Alarm Unit is a device to show the temperature through a sensor inside of ACB.
- The temperature sensor can be installed up to 4 and the output is connected to control terminal blocks.
- It displays the maximum temperature of them and transmits through a network.
- If the temperature is higher than a standard, an alarm can occur.
- Temperature alarm unit communicates with Modbus/RS-485 basically, Profibus-DP needs to be purchased separately.
- Temperature alarm unit is installed on the cradle or the inside of panel.



Temperature alarm

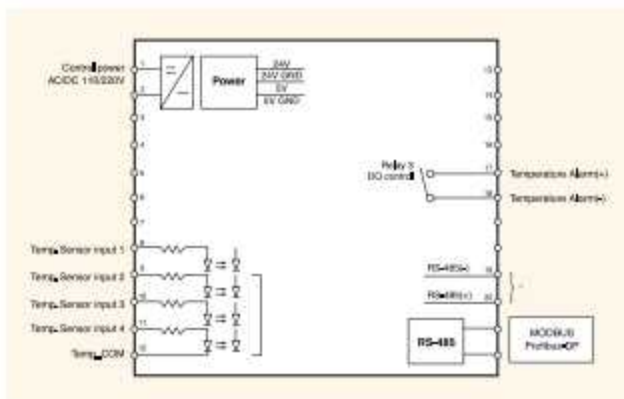

* In case of using Profibus-DP communication, it needs to communicate with ACB through Profibus.

Temperature LED (°C): 10~150 °C
Warning
(Indicates the maximum value)

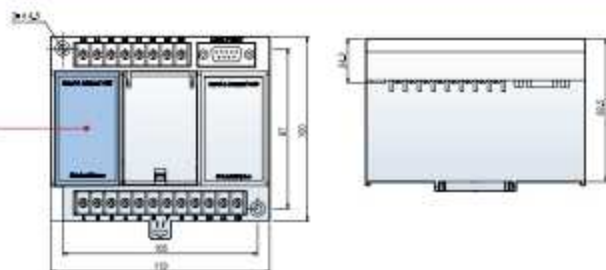

Remote I/O Unit [RCO]



Remote I/O unit

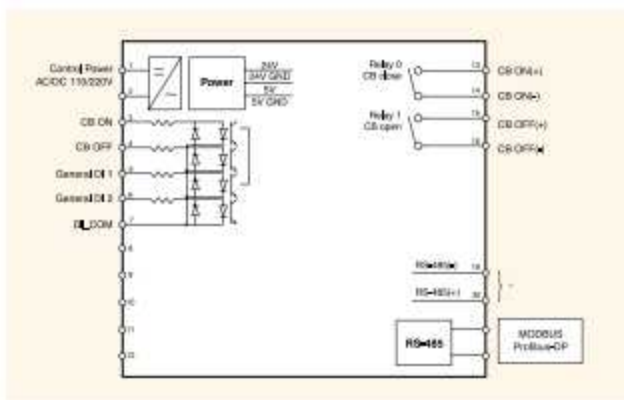
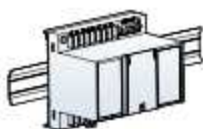

* In case of using Profibus-DP communication, it needs to communicate with ACB for relay.

	Classification	Applied range	Remarks
CB control	Contact switching capacity	AC 230V 16A/DC30V 16A	
	Max. switching capacity	3680VA, 480W	
Alarm	Contact switching capacity	AC 230V 6A/DC25V 6A	Induction load ($\cos\phi = 0.4$, L/R = 7ms)
	Max. switching capacity	1880VA, 150W	

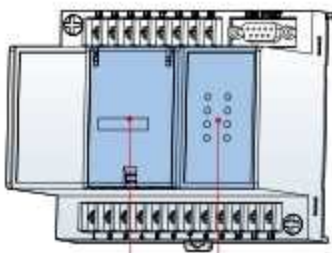

- Baud rate setting
- Comm. address setting
- Temperature setting

- Remote I/O unit has the I/O contact which can trip or close the ACB from the remote site by communication.
- For the General DO, the output of DI1 or DI2 is selectable.
- Remote I/O unit communicates with Modbus/RS-485 communication basically. Profibus-DP need to be purchased separately.
- It supports SBO (Select Before Operation) function and guarantees the control reliability.
- Remote I/O unit can be installed on the cradle of ACB or the inside of panel.

LED	Remarks	
1	DI1	Indicates digital input #1 condition
2	DI2	Indicates digital input #2 condition
3	DO ON	Indicates temperature alarm output is ON
4	DO OFF	Indicates temperature alarm output is OFF
5	CB ON	Indicates circuit break close condition
6	CB OFF	Indicates circuit break open condition
7	RUN LED	Indicates unit run condition
8	CB ERROR	Indicates circuit break terminal Disconnection/control Err condition

Electrical diagram

This diagram is based on "CONNECTED" position of circuit breaker and Opening, Motor charging, Releasing of locking plate should be normal condition.

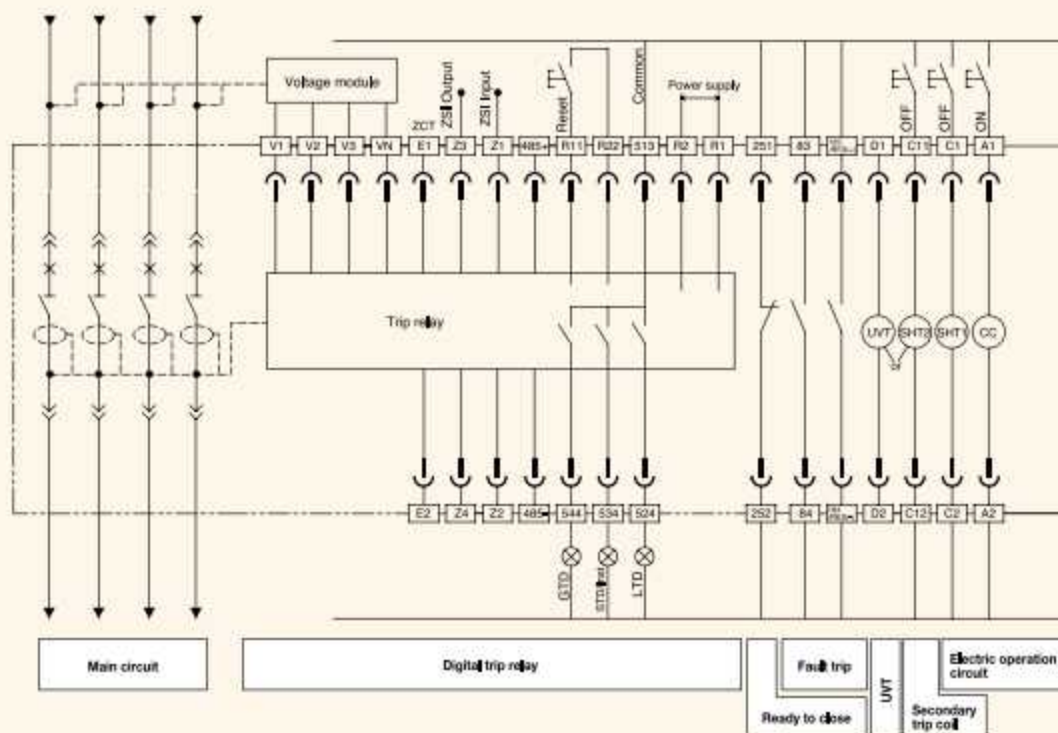

Terminal code description

13	14	63	64	Auxiliary switch "a"
11	12	61	62	Auxiliary switch "b"
413	412			Charged signal
423	422			Charged signal communication
U1	U2			Motor charging
A1	A2			Closing coil
C1	C2			Shunt trip
C11	C12			2nd shunt trip

D1	D2	Voltage input terminal of UVT
83	84	Alarm1 "a"
183	184	Alarm2 "a"
251	252	Ready to close switch
R1	R2	Control power
513	514	Alarm contact
R11	R22	Alarm reset (Trip cause LED, Alarm contact)
4B5	4B5	RS-485 communication

Notes: 1. The diagram is shown with circuit disengaged, all devices open, connected and charged with voltage in normal position.

2. Relay is control switch and charging type is "UVT-Charging".

3. The standard of auxiliary contact is 2A/5. The auxiliary switch is shown in separate diagram is composed of 2A/5. See 50 page for more detail on auxiliary switches.

4. Option:

• Ready to close contact: Trip alarm contact, UVT coil, Fully charged contact, secondary trip coil

• UVT switch, Temperature module, Voltage module, Parallel close open contact, SC1, SC2

5. Please consult us for the use of Z1 (Zero selector interlocking).

6. Refer to the page 44 for the connection of Trip relay and the page 54 for UVT.

7. For connecting RS-485 serial I/O the priority is correct.

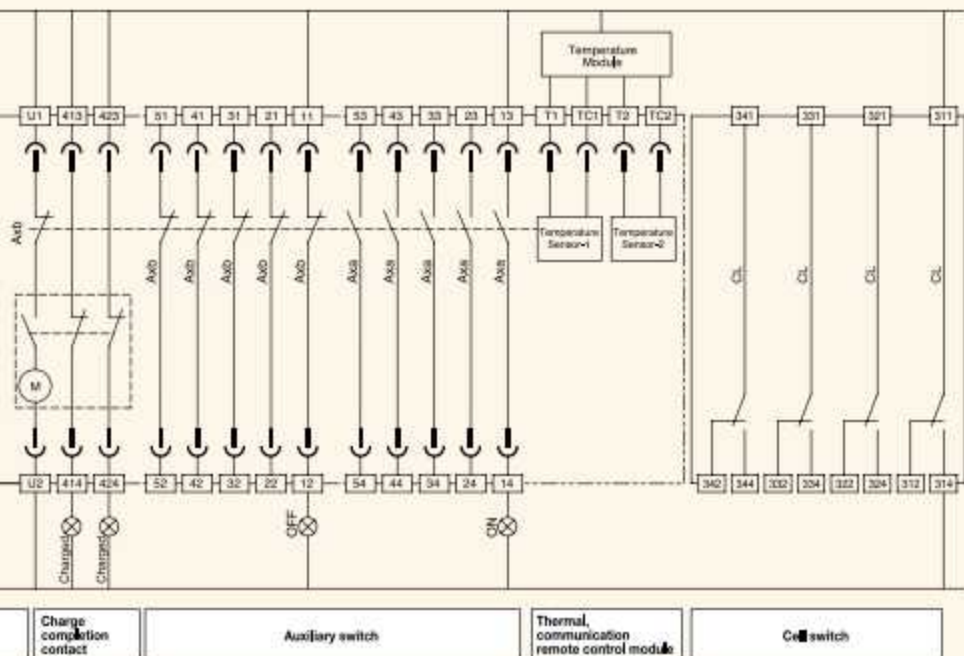

Accessory code description

Z1	Z2	ZSI input
Z3	Z4	ZSI output
E1	E2	ZST
VN	V3	Voltage module
TC1, TC2	T1, T2	Temperature module
311	344	Position switch

Ax	Auxiliary switch
LTD	Long time delay trip indicator
STD / inst	Short time delay/instantaneous
GTD	Ground fault trip indicator
CL	Cell switch
(M)	Motor
(CC)	Closing coil
(ST1)	Shunt tripping device 1
(ST2)	Shunt tripping device 2
(UVT)	UVT coil

—	Internal wiring
—	External wiring (by customer)
⊖	Connector of the control circuit terminal of drawout type

Dimensions

Fixed type 2000AF (630 – 1600A: AKH/AKN/AKS-06 – 16D)

Front view

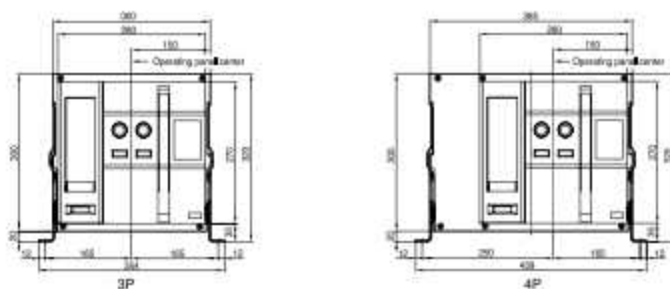

Vertical type

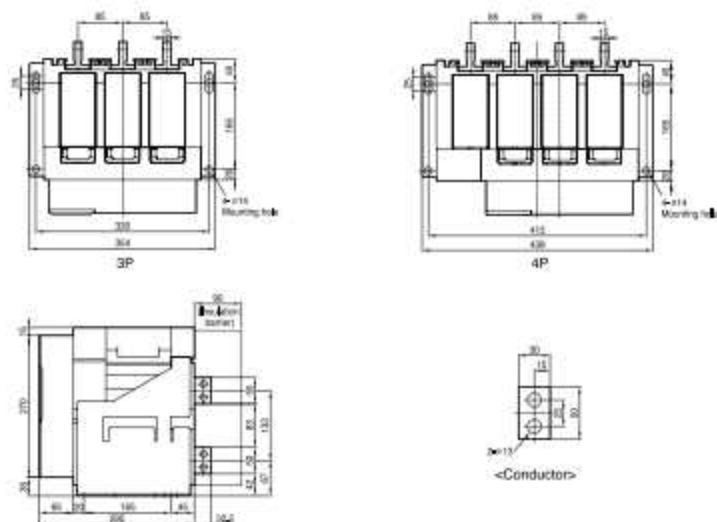

Door Frame: DF (AKH/AKN/AKS-D/E)

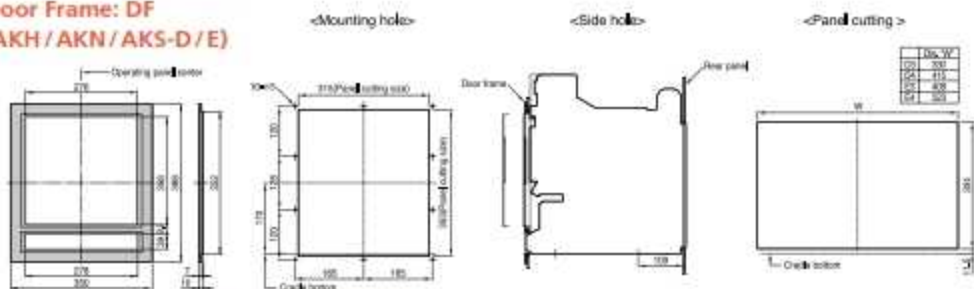

Note: The dimensions are for standard type.

Horizontal type

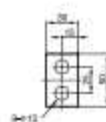
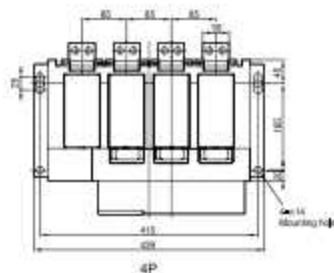
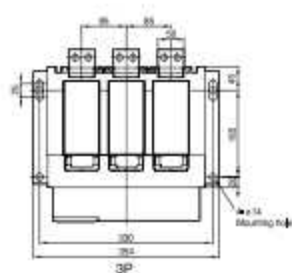

<Conductor>

Front connection type

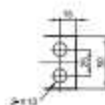
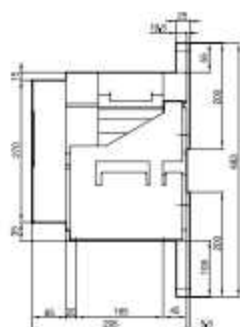
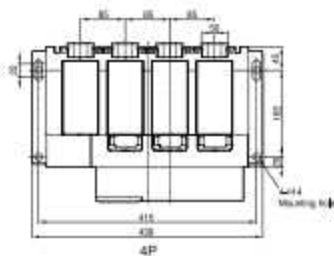
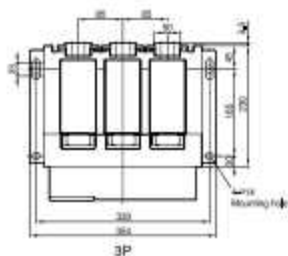

<Conductor>

Dimensions

Draw-out type 2000AF (630 – 1600A: AKH / AKN / AKS-06 – 16D)

Front view

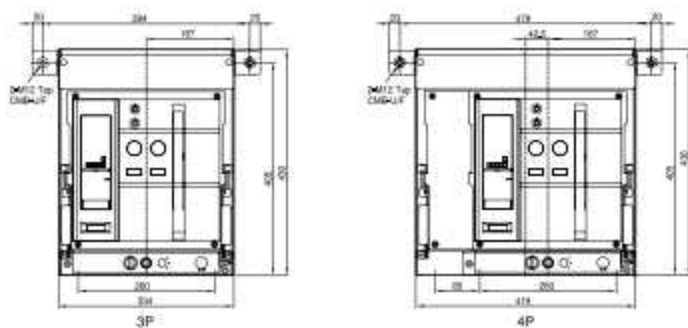

Vertical type

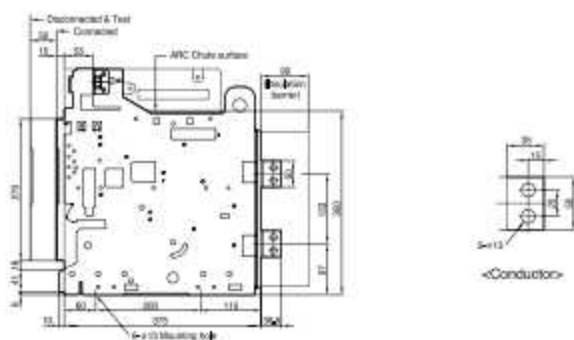
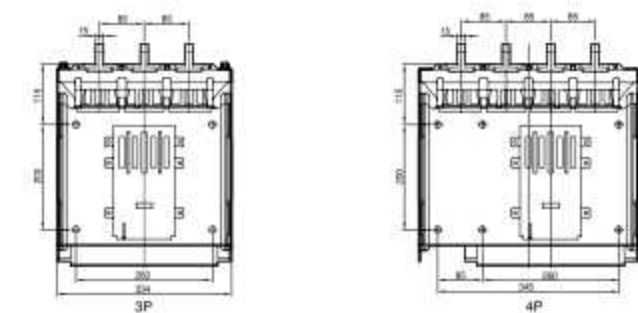

Horizontal type

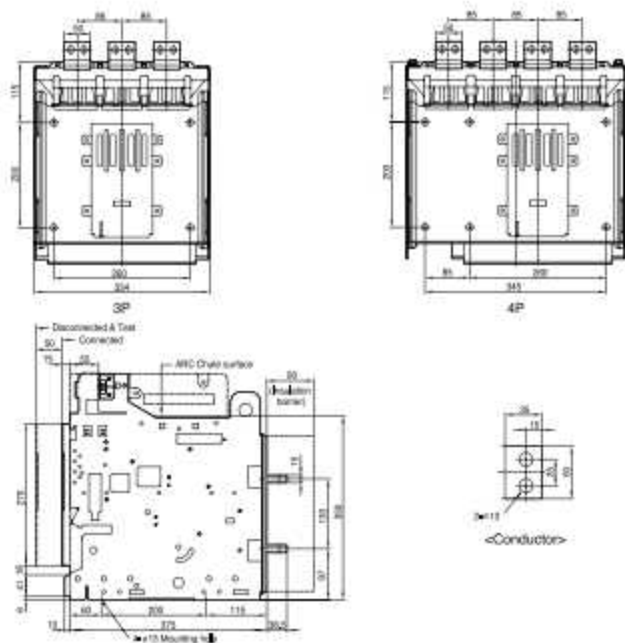

Front connection type

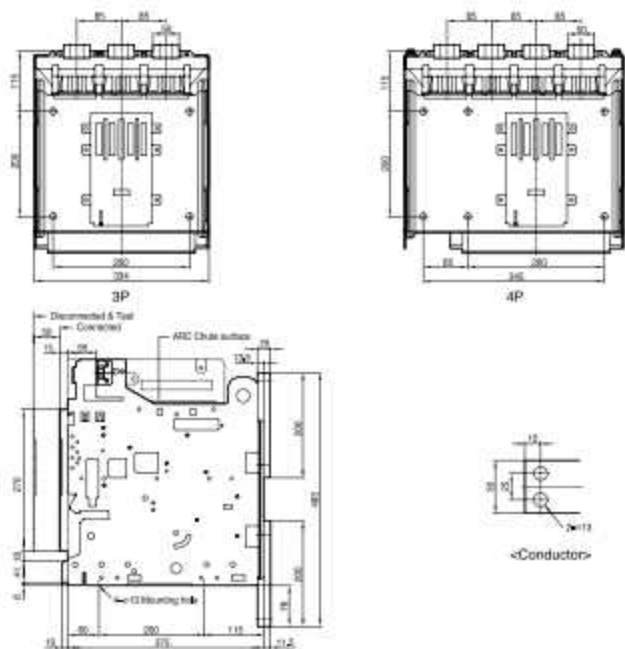

Dimensions

Fixed type 2000AF (2000A: AKH / AKS-20D)

Front view

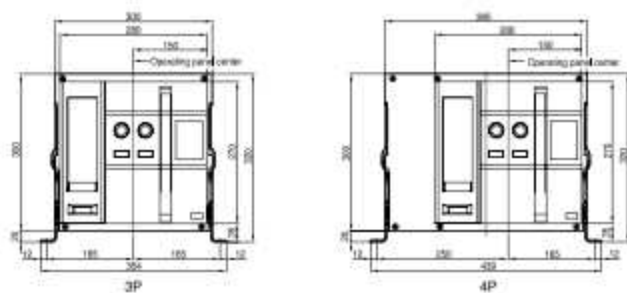

Vertical type

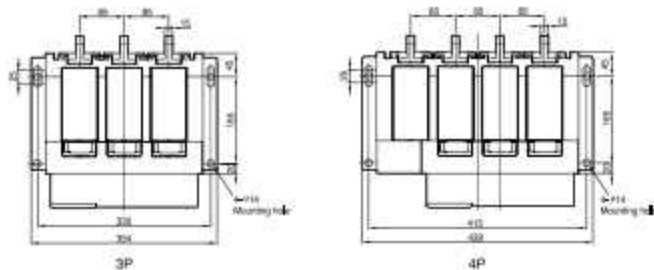

<Conductor>

Dimensions

Fixed type 4000AF (2000 – 3200A: AKH / AKN / AKS-20 – 32E)

Front view

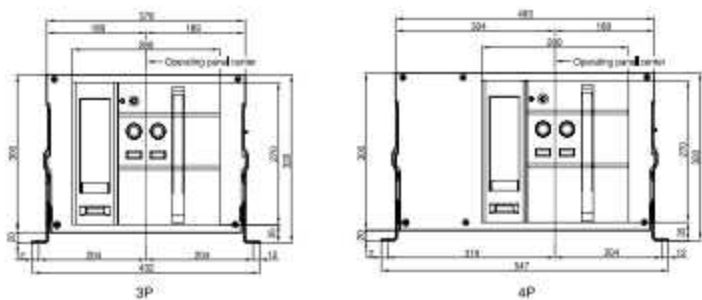

Vertical type

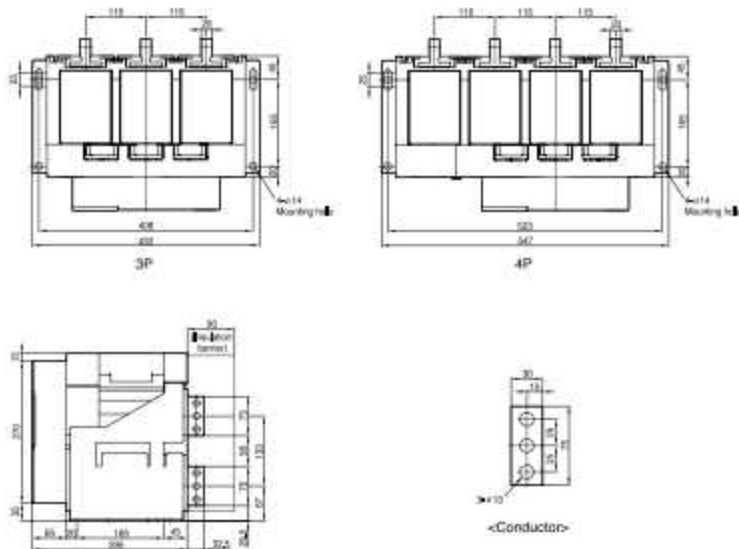

Horizontal type

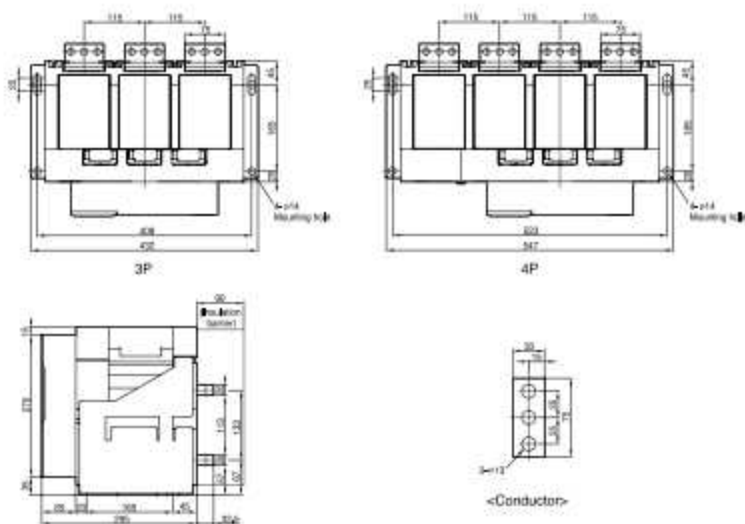

Front connection type

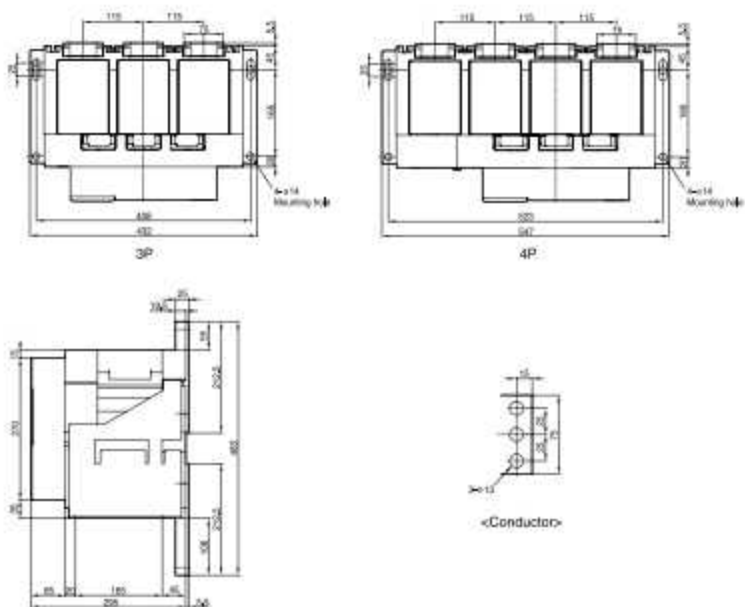

Dimensions

Draw-out type 4000AF (2000 – 3200A: AKH / AKN / AKS-20 – 32E)

Front view

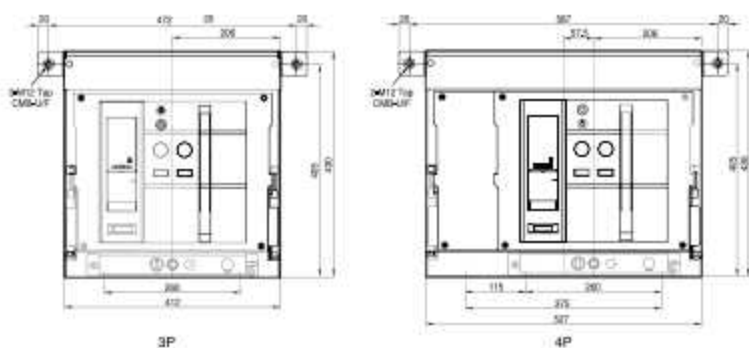

Vertical type

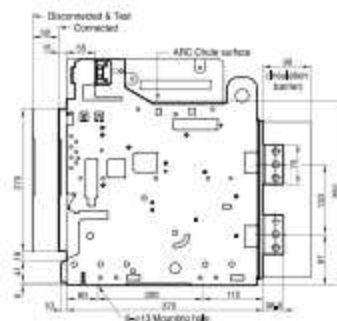
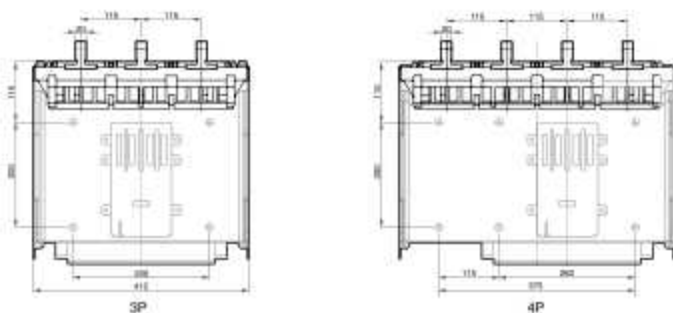

Dimensions

Fixed type 4000AF (4000A: AKH / AKS40E)

Front view

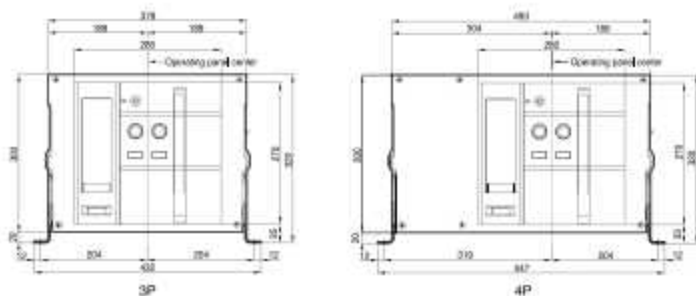

Vertical type

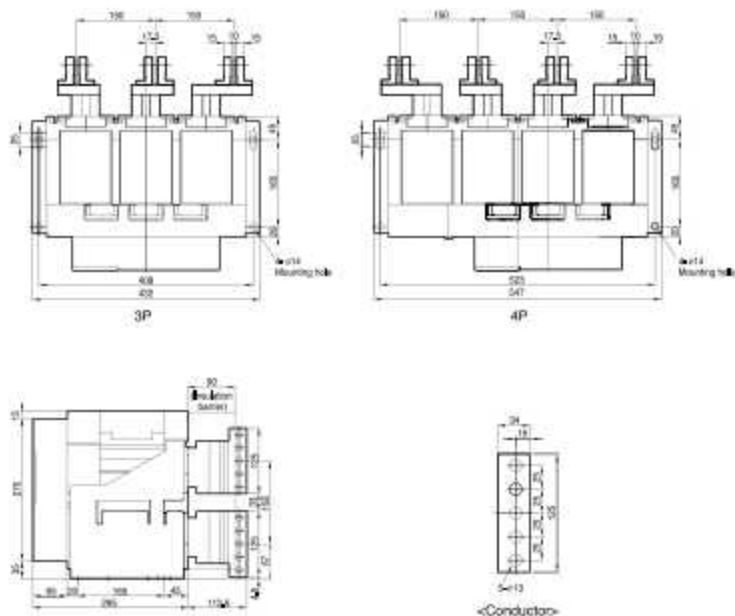

Horizontal type

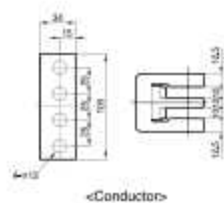
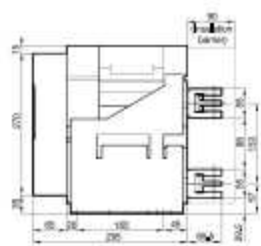
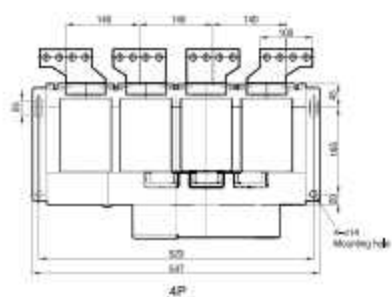
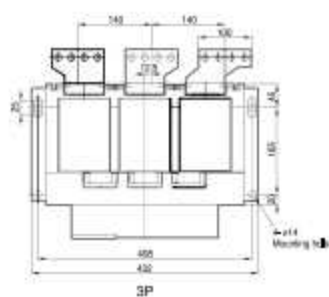

Dimensions

Draw-out type 4000AF (4000A: AKH / AKS-40E)

Front view

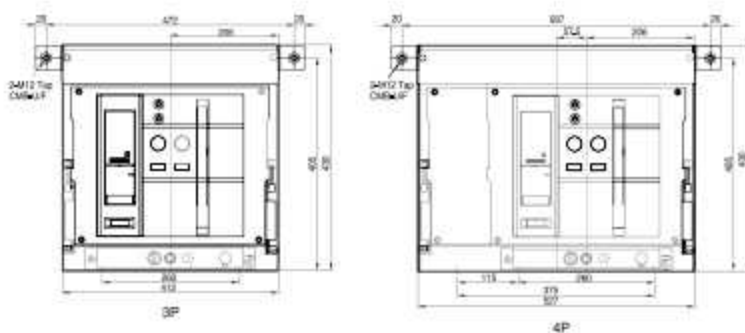

Vertical type

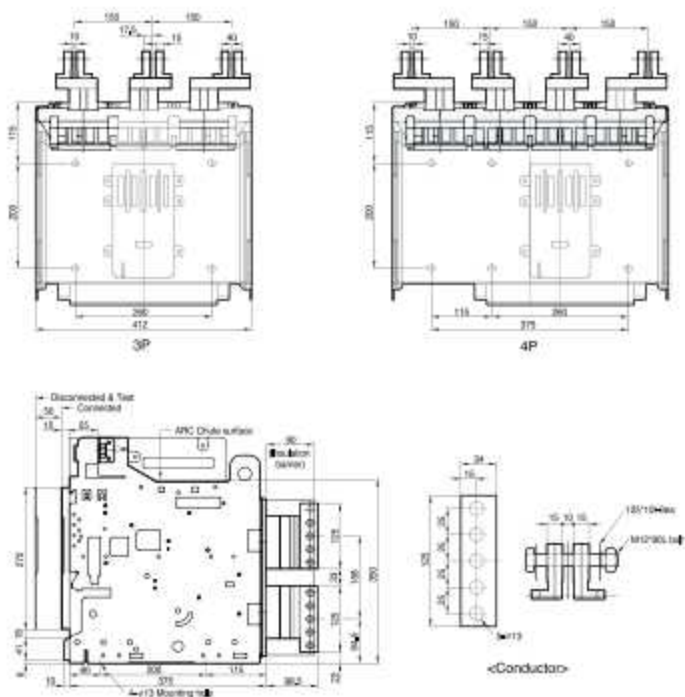

Horizontal type

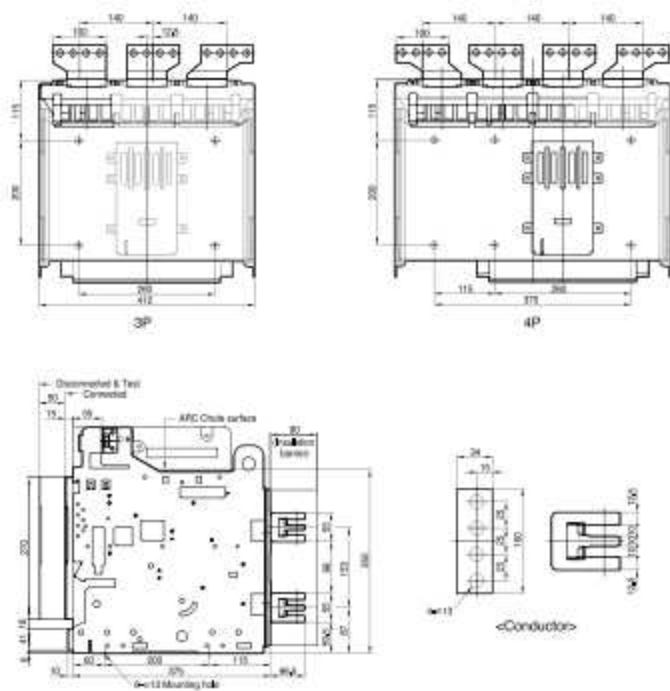

Horizontal type

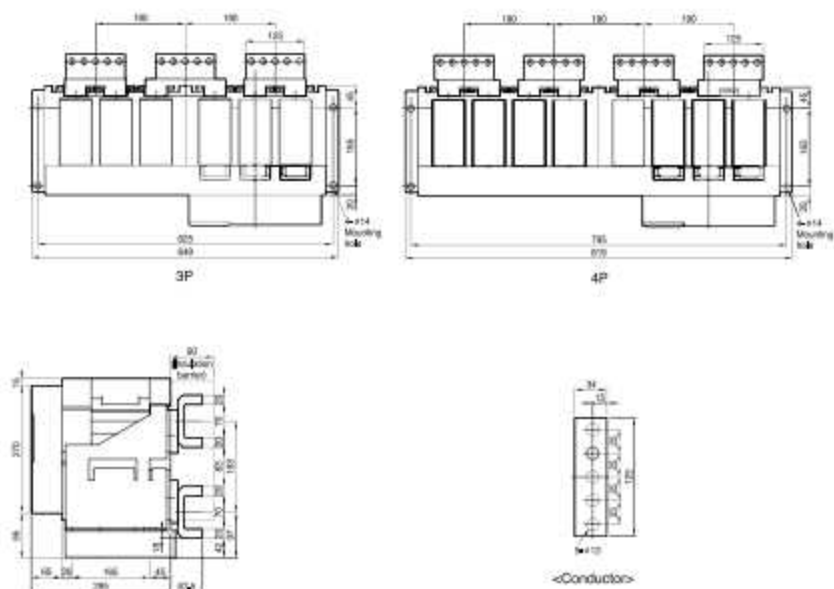

Door Frame: DF (AKH-G, AKS-F)

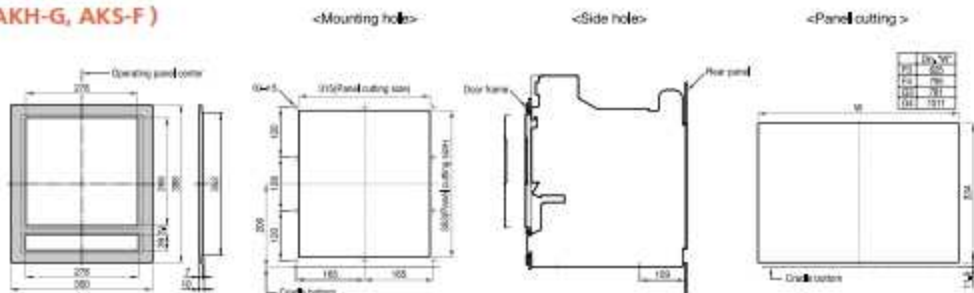

<External size>

Note: The dimensions are for standard type

Dimensions

Draw-out type 5000AF (4000 – 5000A: AKS-40 – 50F)

Front view

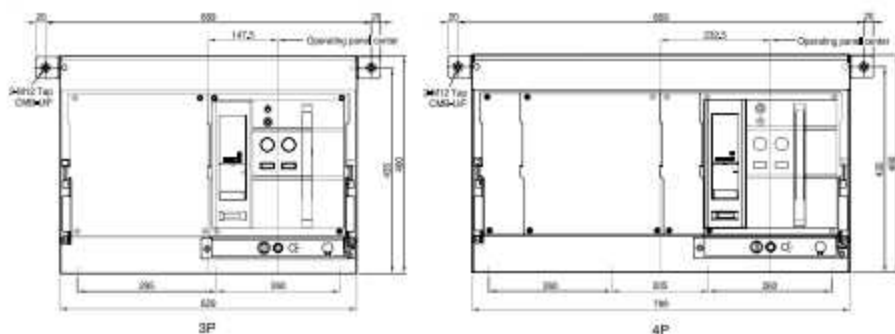

Vertical type

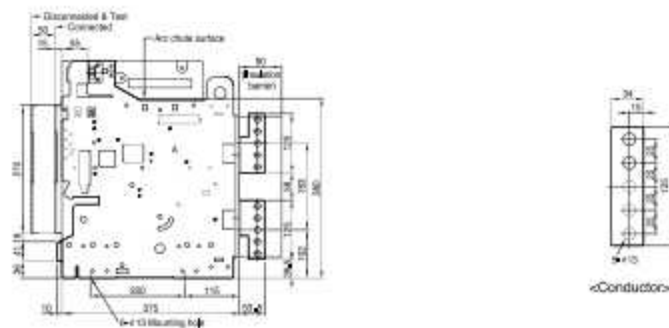
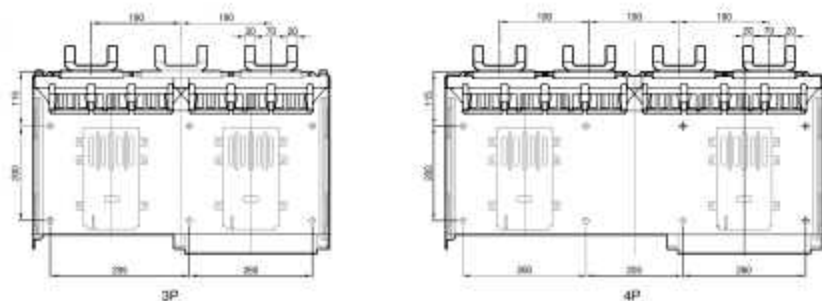

Conductors

Horizontal type

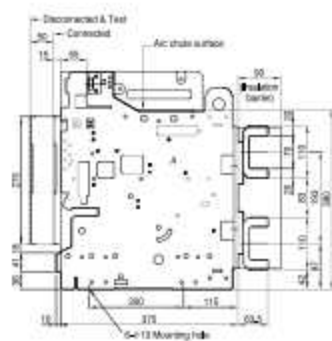
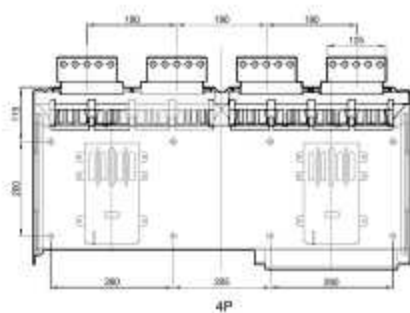
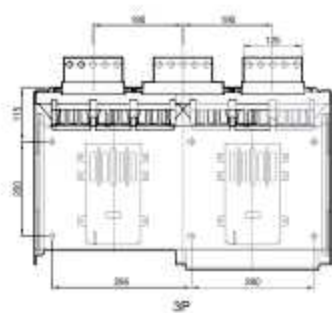

Dimensions

Fixed type 6300AF (4000 – 6300A: AKH / AKS-40 – 50G)

Front view

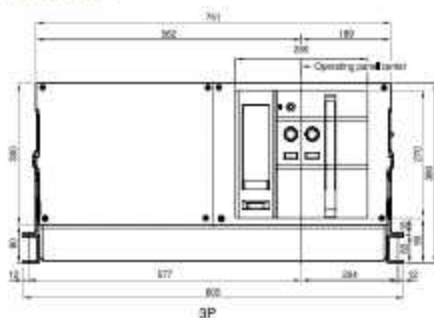

4000A – 5000A

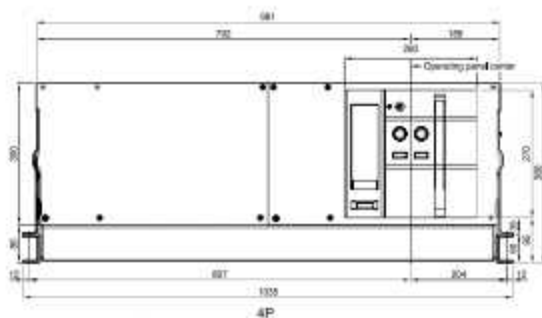
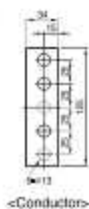

6300A

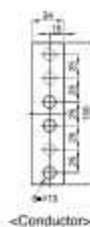

Vertical type

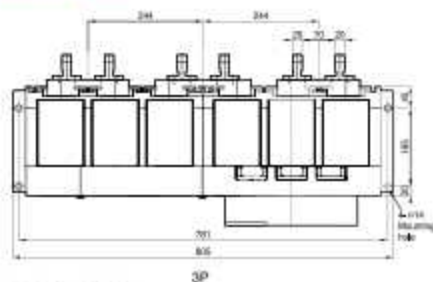

4000A – 5000A

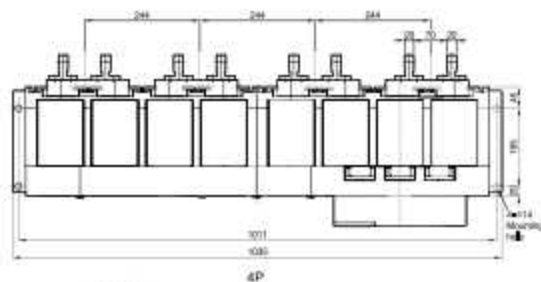
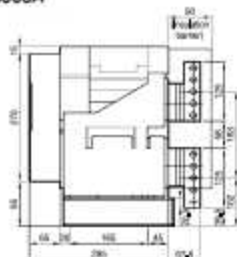

6300A



Horizontal type

4000A - 5000A

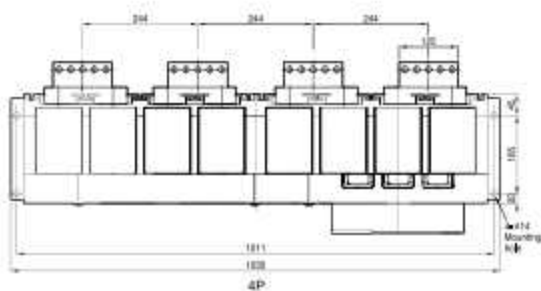
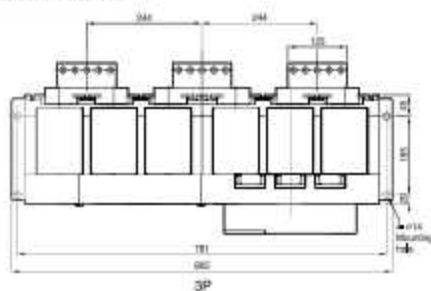

6300A

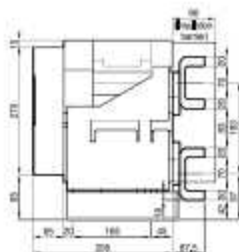
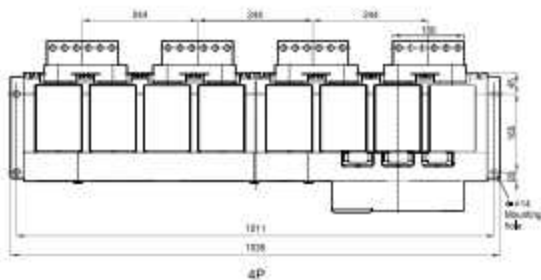
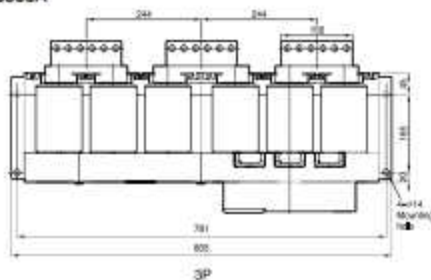

Dimensions

Draw-out type 6300AF (4000 – 6300A: AKH / AKS-40 – 50G)

Front view

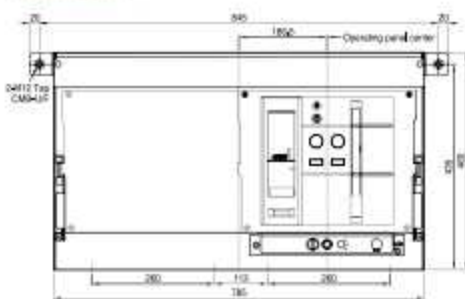

4000A – 5000A

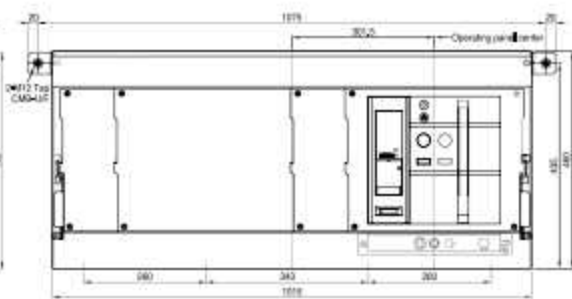
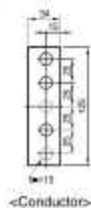

6300A



Vertical type

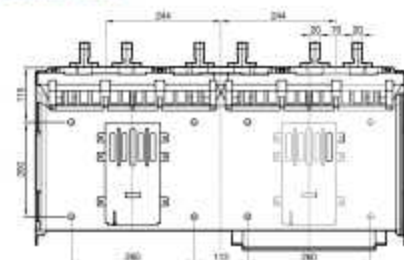

4000A – 5000A

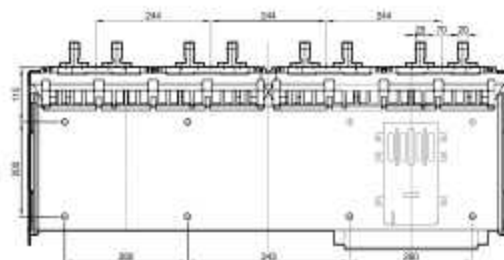

6300A



Horizontal type

4000A - 5000A

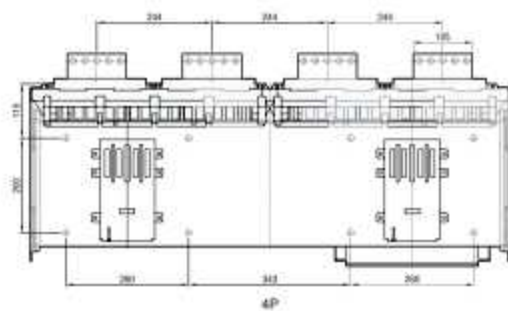
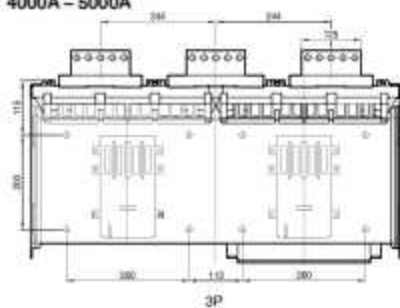

6300A

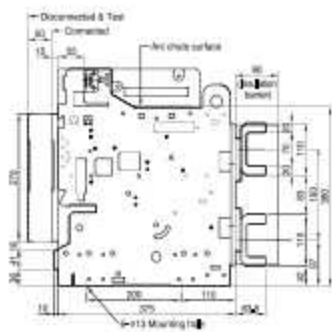
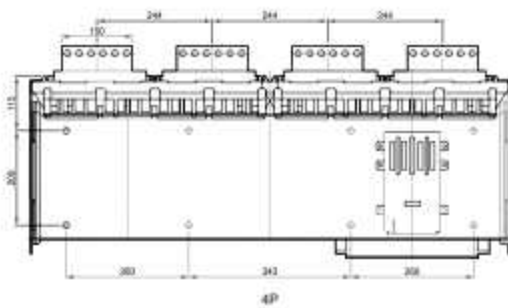
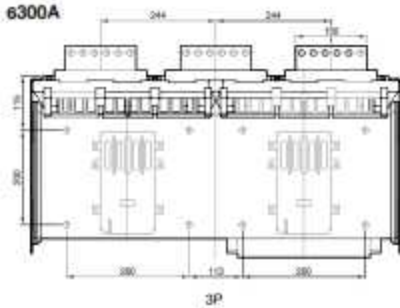

Technical information

Insulation voltage

You should keep the isolation distance between ACB and panel as below table.

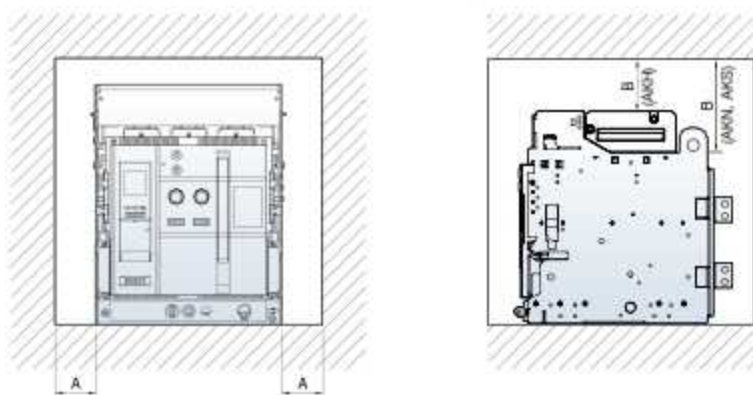

Type		A	B
Fixed	AKN / AKS	50	150
	AKH	50	0
Draw out	AKN / AKS	50	150
	AKH	50	0

Note: When drawing the distribution panel, it is available to use regardless of the distance between ACB and the wall of the panel because ACB (draw-in/out type) outgrows the gap in the line. Check and see Draw-in/out.

Minimum isolation distance

For the safety, all the electric charging parts need to be installed over minimum isolation distance.

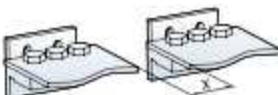

Insulating voltage (U0)	Minimum isolation distance (X min)
600V	8 mm
1000V	14 mm

Temperature derating

The table below indicates the maximum current rating, for each connection type, as a function of the ambient temperature around the circuit breaker and the busbars. Circuit breakers with mixed connections have the same derating as horizontally connected breakers. For ambient temperatures greater than 60°C, consult us. Temperature inside the switchboard around the circuit breaker and its connection: T_i (IEC 60947-2)

Frame	Rated current	ACB terminal	Applicable busbar size											
				Horizontal type					Vertical type					
				40°C	45°C	50°C	55°C	60°C	40°C	45°C	50°C	55°C	60°C	
2000AF AKH-D AKS-D AKN-D	200A	15t x 30 x 1ea	5t x 30 x 2ea	200A	200A	200A	200A	200A	200A	200A	200A	200A	200A	200A
	400A		400A	400A	400A	400A	400A	400A	400A	400A	400A	400A	400A	
	630A		5t x 40 x 2ea	630A	630A	630A	630A	630A	630A	630A	630A	630A	630A	630A
	800A		5t x 50 x 2ea	800A	800A	800A	800A	800A	800A	800A	800A	800A	800A	800A
	1000A		5t x 60 x 2ea	1000A	1000A	1000A	1000A	1000A	1000A	1000A	1000A	1000A	1000A	1000A
	1250A		5t x 80 x 2ea	1250A	1250A	1250A	1250A	1250A	1250A	1250A	1250A	1250A	1250A	1250A
	1600A		5t x 100 x 2ea	1600A	1600A	1600A	1250A	1250A	1600A	1600A	1600A	1600A	1600A	1600A
2000A	15t x 75 x 1ea	5t x 100 x 3ea	-	-	-	-	-	2000A	2000A	2000A	1950A	1900A		
4000AF AKH-E AKS-E	630A	20t x 75 x 1ea	5t x 40 x 2ea	630A	630A	630A	630A	630A	630A	630A	630A	630A	630A	630A
	800A		5t x 50 x 2ea	800A	800A	800A	800A	800A	800A	800A	800A	800A	800A	
	1000A		5t x 60 x 2ea	1000A	1000A	1000A	1000A	1000A	1000A	1000A	1000A	1000A	1000A	
	1250A		5t x 80 x 2ea	1250A	1250A	1250A	1250A	1250A	1250A	1250A	1250A	1250A	1250A	
	1600A		5t x 100 x 2ea	1600A	1600A	1600A	1600A	1600A	1600A	1600A	1600A	1600A	1600A	
	2000A		5t x 100 x 3ea	2000A	2000A	2000A	2000A	2000A	2000A	2000A	2000A	2000A	2000A	
	2500A		5t x 100 x 4ea	2500A	2500A	2500A	2400A	2300A	2500A	2500A	2500A	2450A	2350A	
	3200A	10t x 100 x 3ea	3200A	3200A	3100A	3000A	2900A	3200A	3200A	3200A	3150A	3050A	2950A	
4000A	10t x 100 x 3ea	10t x 125 x 3ea	-	-	-	-	-	4000A	4000A	3950A	3900A	3850A		
5000AF AKS-F	4000A	20t x 125 x 2ea	10t x 100 x 4ea	4000A	4000A	3900A	3800A	3650A	-	-	-	-	-	
	5000A		10t x 100 x 4ea	4000A	4000A	3900A	3750A	3600A	4000A	4000A	3900A	3800A	3700A	
	5000A		10t x 125 x 4ea	5000A	5000A	4900A	4800A	4700A	5000A	5000A	4950A	4850A	4750A	
6300AF AKH-G AKS-G	4000A	20t x 125 x 2ea	10t x 100 x 4ea	4000A	4000A	4000A	3900A	3800A	4000A	4000A	4000A	3950A	3850A	
	6300A		10t x 125 x 4ea	5000A	5000A	5000A	4900A	4800A	5000A	5000A	5000A	4950A	4850A	
AKS-G	6300A	20t x 150 x 2ea	10t x 130 x 4ea	6300A	6300A	6200A	6100A	6000A	6300A	6300A	6250A	6152A	6050A	

Technical information

Operating condigions

Ambient temperature

ACB devices can operate under the following temperature conditions

- The electrical and mechanical characteristics are stipulated for an ambient temperature of -5°C to +40°C
- The average temperature should be within +35°C
- Reduce the continuous conducting current when the temperature is over 45°C (refer to temperature derating)
- Storage condition: -20°C to +60°C is recommended.

Altitude

ACB is designed for operation at altitudes under 2000m. At altitudes higher than 2000m, emitting heat is lowered and operating voltage, continuous current capacity, and breaking capacity will be reduced. Durability of the insulation is also reduced according to the atmosphere pressure. According to the below table, change the ratings upon a service condition.

Item	Altitude [m]			
	2000m	3000m	4000m	5000m
Withstand voltage [V]	3500	3150	2500	2100
Average insulating voltage[V]	1000	900	700	600
Max. using voltage [V]	690	590	520	400
Current compensation constant	1 x I _n	0.99 x I _n	0.96 x I _n	0.94 x I _n

Environment

Under clea air;

Maximum temperature +40°C (relative humidity should be under 85%)

Maximum temperature +20°C (relative humidity should be under 90%)

Do not apply under corrosive or ammonia gas circumstances

(H₂S ≤ 0.01ppm, SO₂ ≤ 0.01ppm, NH₃ ≤ a few ppm)

*Extreme atmosphere conditions

Under high temperature and/or high humidity, the insulatin durability, electrical and mechanical features could be deteriorated. At this conditions, increasing corrosion-resistant dealing needs. Corrosion- resistant parts need under this conditions.

Time chart

Long time

X \ Y	0.5	1	2	4	8	12	16	20
1.11	58806	117011	235223	470445	940890	1411335	1881780	2352225
1.13	30041	72082	144163	288326	576652	864978	1153305	1441631
1.20	20827	53654	107308	214615	429231	643846	858461	1073077
1.25	21777	43553	87106	174212	348424	522636	696848	871060
1.30	18408	36817	73634	147268	294535	441803	589071	736338
1.35	15497	31895	63789	127579	255157	382736	510314	637893
1.40	14049	28098	56197	112393	224787	337180	449573	561967
1.45	12532	25063	50126	100252	200504	300756	401009	501261
1.50	11268	22537	45145	90290	180580	270870	361160	451450
1.55	10244	20488	40977	81954	163907	245861	327814	409768
1.60	9359	18717	37434	74869	149737	224606	299474	374343
1.65	8596	17193	34386	68771	137542	206313	275084	343855
1.70	7934	15867	31734	63488	126956	190404	253873	317341
1.75	7352	14704	29408	58815	117631	178446	235261	294077
1.80	6838	13675	27351	54702	109404	164106	218808	273509
1.85	6380	12760	25521	51041	102082	153123	204164	255205
1.90	5970	11941	23882	47764	95528	143292	191056	238820
1.95	5602	11204	22408	44815	89630	134446	179261	224076
2.00	5269	10537	21075	42150	84299	126449	168598	210748
2.05	4966	9932	19805	39370	79459	119189	158919	198049
2.10	4691	9381	18702	37525	75049	112574	150099	187023
2.15	4439	8877	17754	35508	71017	106525	142034	177542
2.20	4207	8415	16829	33959	67318	100976	134635	168294
2.25	3995	7989	15979	31957	63914	95871	127829	159786
2.30	3798	7597	15194	30387	60775	91162	121550	151937
2.35	3617	7234	14468	28936	57871	86807	115742	144678
2.40	3449	6897	13795	27590	55180	82769	110359	137949
2.45	3292	6585	13170	26339	52679	79018	105358	131657
2.50	3147	6294	12588	25176	50351	75527	100702	125878
2.55	3011	6022	12045	24090	48180	72269	96359	120449
2.60	2884	5769	11538	23075	46151	69226	92301	115377
2.65	2766	5531	11063	22120	44251	66377	88503	110628
2.70	2654	5309	10618	21235	42471	63706	84941	106177
2.75	2550	5100	10200	20399	40799	61198	81597	101997
2.80	2452	4903	9807	19613	39220	58840	78453	98066
2.85	2359	4718	9436	18873	37746	56619	75791	94364
2.90	2272	4544	9087	18175	36350	54524	72699	90874
2.95	2189	4379	8758	17516	35032	52547	70063	87579
3.00	2112	4223	8446	16893	33786	50679	67572	84464
3.05	2038	4076	8152	16303	32607	48910	65214	81517
3.10	1968	3936	7872	15745	31490	47235	62980	78725
3.15	1902	3804	7608	15215	30431	45645	60862	76077
3.20	1839	3678	7356	14713	29425	44138	58851	73563
3.25	1779	3559	7117	14235	28470	42705	56940	71175
3.30	1723	3445	6890	13781	27561	41342	55122	68903
3.35	1669	3337	6674	13348	26696	40044	53392	66741
3.40	1617	3234	6468	12936	25872	38808	51744	64680
3.45	1568	3136	6272	12543	25086	37629	50172	62715
3.50	1521	3042	6084	12168	24336	36504	48672	60841
3.55	1476	2952	5905	11810	23620	35430	47240	59050
3.60	1433	2867	5734	11468	22935	34403	45871	57338
3.65	1393	2785	5570	11140	22281	33421	44561	55702
3.70	1353	2707	5413	10827	21654	32481	43308	54135
3.75	1316	2632	5263	10527	21054	31581	42108	52634
3.80	1280	2560	5120	10239	20479	30718	40957	51196
3.85	1245	2491	4982	9963	19927	29890	39854	49817
3.90	1212	2425	4849	9699	19398	29096	38795	48494

X \ Y	0.5	1	2	4	8	12	16	20
3.95	1181	2361	4722	9445	18889	28334	37779	47223
4.00	1150	2300	4600	9201	18401	27602	36802	46003
4.05	1121	2241	4483	8966	17952	26896	35864	44830
4.10	1093	2185	4370	8740	17481	26221	34961	43701
4.15	1065	2131	4262	8523	17046	25569	34092	42615
4.20	1039	2079	4157	8314	16628	24942	33256	41570
4.25	1014	2028	4056	8113	16225	24338	32451	40563
4.30	990	1980	3959	7919	15837	23756	31674	39593
4.35	966	1933	3866	7731	15463	23194	30926	38667
4.40	944	1888	3776	7551	15102	22653	30204	37755
4.45	922	1844	3688	7377	14754	22131	29507	36884
4.50	901	1802	3604	7209	14417	21626	28835	36043
4.55	881	1762	3523	7046	14093	21139	28185	35231
4.60	861	1722	3445	6889	13779	20668	27557	34447
4.65	842	1684	3369	6738	13475	20213	26951	33688
4.70	824	1648	3295	6591	13182	19773	26364	32955
4.75	806	1612	3223	6449	12898	19347	25796	32245
4.80	789	1578	3156	6312	12624	18935	25247	31559
4.85	772	1545	3089	6179	12358	18536	24715	30894
4.90	756	1513	3025	6050	12100	18150	24200	30250
4.95	741	1481	2963	5925	11851	17776	23701	29627
5.00	726	1451	2902	5804	11609	17413	23218	29022
5.05	711	1422	2844	5687	11374	17062	22749	28436
5.10	697	1393	2787	5574	11147	16721	22294	27868
5.15	683	1366	2732	5463	10927	16390	21853	27317
5.20	670	1339	2678	5356	10713	16069	21425	26782
5.25	657	1313	2626	5252	10505	15757	21010	26262
5.30	644	1288	2576	5152	10303	15455	20607	25758
5.35	632	1263	2527	5054	10107	15161	20215	25268
5.40	620	1240	2479	4959	9917	14876	19834	24793
5.45	608	1217	2433	4866	9732	14598	19464	24320
5.50	597	1194	2388	4776	9552	14329	19105	23881
5.55	586	1172	2344	4689	9378	14066	18755	23444
5.60	575	1151	2302	4604	9207	13811	18415	23019
5.65	565	1130	2261	4521	9042	13563	18084	22605
5.70	555	1110	2220	4441	8881	13322	17762	22203
5.75	545	1091	2181	4362	8724	13087	17449	21811
5.80	536	1071	2143	4286	8572	12858	17144	21430
5.85	526	1053	2106	4212	8423	12635	16847	21058
5.90	517	1035	2070	4139	8279	12418	16557	20697
5.95	509	1017	2034	4069	8138	12206	16275	20344
6.00	500	1000	2000	4000	8000	12000	16000	20001
6.05	482	982	1967	3932	7866	11799	15733	19666
6.10	483	967	1934	3868	7736	11604	15471	19339
6.15	476	951	1902	3804	7608	11413	15217	19021
6.20	468	936	1871	3742	7484	11226	14968	18710
6.25	460	920	1841	3682	7363	11045	14726	18408
6.30	453	906	1811	3622	7245	10867	14490	18112
6.35	446	891	1782	3565	7129	10694	14259	17823
6.40	439	877	1754	3508	7017	10525	14034	17542
6.45	432	863	1727	3453	6907	10360	13814	17267
6.50	425	850	1700	3400	6799	10199	13599	16998
6.55	418	837	1674	3347	6694	10042	13389	16736
6.60	412	824	1648	3296	6592	9888	13184	16480
6.65	406	811	1623	3246	6492	9738	12984	16230
6.70	400	799	1598	3197	6394	9591	12788	15983
6.75	394	787	1573	3149	6298	9447	12597	15746

Time chart

Long time

x \ t	0.5	1	2	4	8	12	16	20
6.80	388	776	1551	3102	6205	9307	12410	15512
6.85	382	764	1528	3057	6113	9170	12227	15283
6.90	376	753	1506	3012	6024	9036	12048	15060
6.95	371	742	1484	2968	5936	8905	11873	14841
7.00	366	731	1463	2925	5851	8776	11702	14627
7.05	360	721	1442	2884	5767	8651	11534	14418
7.10	355	711	1421	2843	5685	8528	11371	14213
7.15	350	701	1401	2803	5605	8408	11210	14013
7.20	345	691	1382	2763	5527	8290	11053	13816
7.25	341	681	1362	2725	5450	8175	10899	13624
7.30	336	672	1344	2687	5374	8062	10749	13436
7.35	331	663	1325	2650	5301	7951	10601	13252
7.40	327	654	1307	2614	5229	7843	10457	13071
7.45	322	645	1289	2579	5158	7737	10316	12895
7.50	318	636	1272	2544	5089	7633	10177	12721
7.55	314	628	1255	2510	5021	7531	10041	12552
7.60	310	619	1239	2477	4954	7431	9908	12385
7.65	306	611	1222	2444	4889	7333	9778	12222
7.70	302	603	1206	2412	4825	7237	9650	12062
7.75	298	595	1191	2381	4762	7143	9524	11906
7.80	294	588	1175	2350	4701	7051	9401	11752
7.85	290	580	1160	2320	4640	6961	9281	11601
7.90	286	573	1145	2291	4581	6872	9163	11453
7.95	283	565	1131	2262	4523	6785	9047	11308
8.00	279	558	1117	2233	4466	6700	8933	11166
8.05	276	551	1103	2205	4411	6616	8821	11026
8.10	272	544	1089	2178	4356	6534	8712	10889
8.15	269	538	1076	2151	4302	6453	8604	10755
8.20	266	531	1062	2125	4249	6374	8498	10623
8.25	262	525	1049	2099	4197	6296	8395	10494
8.30	259	518	1037	2073	4147	6220	8293	10366
8.35	256	512	1024	2048	4097	6145	8193	10242
8.40	253	506	1012	2024	4048	6071	8095	10119
8.45	250	500	1000	2000	3999	5999	7999	9998
8.50	247	494	988	1976	3952	5928	7904	9880
8.55	244	488	976	1953	3906	5858	7811	9764
8.60	241	482	965	1930	3860	5790	7720	9650
8.65	238	477	954	1908	3815	5723	7630	9538
8.70	236	471	943	1886	3771	5657	7542	9428
8.75	233	466	932	1864	3728	5592	7455	9319
8.80	230	461	921	1843	3685	5528	7370	9213
8.85	228	455	911	1822	3643	5465	7287	9108
8.90	225	450	901	1801	3602	5403	7204	9005
8.95	223	445	890	1781	3562	5343	7123	8904
9.00	220	440	880	1761	3522	5283	7044	8805
9.05	218	435	871	1741	3483	5224	6966	8707
9.10	215	431	861	1722	3444	5167	6889	8611
9.15	213	426	852	1703	3407	5110	6813	8516
9.20	211	421	842	1685	3369	5054	6739	8423
9.25	208	417	833	1666	3333	4999	6666	8332
9.30	206	412	824	1648	3297	4945	6594	8242
9.35	204	408	815	1631	3261	4892	6523	8153
9.40	202	403	807	1613	3227	4840	6453	8066
9.45	200	399	798	1596	3192	4788	6384	7981
9.50	197	395	790	1579	3159	4738	6317	7896
9.55	195	391	781	1563	3125	4688	6251	7813
9.60	193	387	773	1546	3093	4639	6185	7732

x \ t	0.5	1	2	4	8	12	16	20
9.65	191	383	765	1530	3060	4591	6121	7651
9.70	189	379	757	1514	3029	4543	6058	7572
9.75	187	375	749	1499	2998	4496	5995	7494
9.80	185	371	742	1483	2967	4450	5934	7417
9.85	184	367	734	1468	2937	4405	5873	7342
9.90	182	363	727	1453	2907	4360	5814	7267
9.95	180	360	719	1439	2878	4316	5755	7194
10.00	178	356	712	1424	2849	4273	5697	7122

Short time

x \ t	0.1	0.2	0.3	0.4	x \ t	0.1	0.2	0.3	0.4
1.40	5102	10204	15306	20408	3.40	803	1730	2595	3460
1.45	4756	9512	14209	19025	3.45	840	1686	2520	3301
1.50	4444	8889	13333	17778	3.50	816	1633	2449	3205
1.55	4162	8325	12487	16649	3.55	793	1587	2380	3174
1.60	3906	7813	11719	15625	3.60	772	1543	2315	3086
1.65	3673	7346	11019	14692	3.65	751	1501	2252	3002
1.70	3460	6920	10381	13841	3.70	730	1461	2191	2922
1.75	3265	6531	9796	13061	3.75	711	1422	2133	2844
1.80	3080	6173	9259	12346	3.80	693	1385	2078	2770
1.85	2922	5844	8766	11687	3.85	675	1349	2024	2699
1.90	2770	5540	8310	11080	3.90	657	1315	1972	2630
1.95	2630	5260	7890	10519	3.95	641	1282	1923	2564
2.00	2500	5000	7500	10000	4.00	625	1250	1875	2500
2.05	2380	4759	7139	9518	4.05	610	1219	1829	2439
2.10	2268	4535	6803	9070	4.10	595	1190	1785	2380
2.15	2163	4327	6490	8653	4.15	581	1161	1742	2323
2.20	2066	4132	6198	8264	4.20	567	1134	1701	2268
2.25	1975	3951	5926	7901	4.25	554	1107	1661	2215
2.30	1889	3781	5671	7561	4.30	541	1082	1622	2163
2.35	1811	3622	5432	7243	4.35	528	1057	1585	2114
2.40	1736	3472	5208	6944	4.40	517	1033	1550	2066
2.45	1666	3332	4998	6664	4.45	505	1010	1515	2020
2.50	1600	3200	4800	6400	4.50	494	988	1481	1975
2.55	1538	3076	4614	6151	4.55	483	966	1449	1932
2.60	1479	2959	4438	5917	4.60	473	945	1418	1890
2.65	1424	2848	4272	5696	4.65	462	923	1387	1850
2.70	1372	2743	4115	5487	4.70	453	905	1358	1811
2.75	1322	2645	3967	5289	4.75	443	886	1330	1773
2.80	1276	2551	3827	5102	4.80	434	868	1302	1736
2.85	1231	2462	3693	4925	4.85	425	850	1275	1700
2.90	1189	2378	3567	4756	4.90	416	833	1249	1666
2.95	1149	2298	3447	4596	4.95	408	816	1224	1632
3.00	1111	2222	3333	4444	5.00	400	800	1200	1600
3.05	1075	2150	3225	4300	5.05	392	784	1176	1568
3.10	1041	2081	3122	4162	5.10	384	769	1153	1538
3.15	1008	2016	3023	4031	5.15	377	754	1131	1508
3.20	977	1953	2930	3906	5.20	370	740	1109	1479
3.25	947	1893	2840	3787	5.25	363	726	1088	1451
3.30	918	1837	2755	3673	5.30	356	712	1068	1424
3.35	891	1782	2673	3564	5.35	349	699	1048	1398

Short time

$\frac{x}{R} \text{ 均}$	0.1	0.2	0.3	0.4	$\frac{x}{R} \text{ 均}$	0.1	0.2	0.3	0.4
5.40	343	686	1029	1372	8.25	147	294	441	588
5.45	337	673	1010	1347	8.30	145	290	435	581
5.50	331	661	992	1322	8.35	143	287	430	574
5.55	325	649	974	1299	8.40	142	283	425	567
5.60	319	638	957	1276	8.45	140	280	420	560
5.65	313	627	940	1253	8.50	138	277	415	554
5.70	308	616	923	1231	8.55	137	274	410	547
5.75	302	605	907	1210	8.60	135	270	406	541
5.80	297	595	892	1189	8.65	134	267	401	535
5.85	292	584	877	1169	8.70	132	264	396	528
5.90	287	575	862	1149	8.75	131	261	392	522
5.95	282	565	847	1130	8.80	129	258	387	517
6.00	278	556	833	1111	8.85	128	255	383	511
6.05	273	546	820	1093	8.90	126	252	379	505
6.10	269	537	806	1075	8.95	125	250	375	499
6.15	264	529	793	1058	9.00	123	247	370	494
6.20	260	520	780	1041	9.05	122	244	366	488
6.25	256	512	768	1024	9.10	121	242	362	483
6.30	252	504	756	1008	9.15	119	239	358	478
6.35	248	496	744	992	9.20	118	236	354	473
6.40	244	488	732	977	9.25	117	234	351	467
6.45	240	481	721	961	9.30	116	231	347	462
6.50	237	473	710	947	9.35	114	229	343	456
6.55	233	466	699	932	9.40	113	226	340	453
6.60	230	459	689	918	9.45	112	224	336	448
6.65	226	452	678	905	9.50	111	222	332	443
6.70	223	446	668	891	9.55	110	219	329	439
6.75	219	439	658	878	9.60	109	217	326	434
6.80	216	433	649	865	9.65	107	215	322	430
6.85	213	428	639	852	9.70	106	213	319	425
6.90	210	420	630	840	9.75	105	210	316	421
6.95	207	414	621	828	9.80	104	208	312	416
7.00	204	408	612	816	9.85	103	206	309	412
7.05	201	402	604	805	9.90	102	204	306	408
7.10	198	397	595	793	9.95	101	202	303	404
7.15	196	391	587	782	10.00	100	200	300	400
7.20	193	386	579	772					
7.25	190	380	571	761					
7.30	188	375	563	751					
7.35	185	370	555	740					
7.40	183	365	548	730					
7.45	180	360	541	721					
7.50	178	356	533	711					
7.55	175	351	526	702					
7.60	173	348	519	693					
7.65	171	342	513	683					
7.70	169	337	506	675					
7.75	166	333	499	666					
7.80	164	329	493	657					
7.85	162	325	487	649					
7.90	160	320	481	641					
7.95	158	316	475	633					
8.00	156	312	469	625					
8.05	154	309	463	617					
8.10	152	305	457	610					
8.15	151	301	452	602					
8.20	149	297	446	595					

Ground fault

$\frac{x}{R} \text{ 均}$	0.1	0.2	0.3	0.4	$\frac{x}{R} \text{ 均}$	0.1	0.2	0.3	0.4	$\frac{x}{R} \text{ 均}$	0.1	0.2	0.3	0.4
0.20	2300	5000	7500	10000	0.77	109	337	506	675					
0.21	2268	4935	7403	9970	0.78	104	329	493	657					
0.22	2066	4132	6198	8264	0.79	100	320	481	641					
0.23	1890	3781	5671	7501	0.80	106	313	469	625					
0.24	1736	3472	5208	6944	0.81	152	305	457	610					
0.25	1600	3200	4800	6400	0.82	149	297	446	595					
0.26	1479	2959	4438	5917	0.83	145	290	435	581					
0.27	1372	2743	4115	5487	0.84	142	283	425	567					
0.28	1278	2551	3827	5102	0.85	138	277	415	554					
0.29	1189	2378	3567	4756	0.86	135	270	406	541					
0.30	1111	2222	3333	4444	0.87	132	264	396	528					
0.31	1041	2081	3122	4162	0.88	129	258	387	517					
0.32	977	1953	2930	3906	0.89	126	252	379	505					
0.33	918	1837	2755	3673	0.90	123	247	370	494					
0.34	865	1730	2595	3460	0.91	121	242	362	483					
0.35	816	1633	2449	3265	0.92	118	236	354	473					
0.36	772	1543	2315	3086	0.93	116	231	347	462					
0.37	730	1461	2191	2922	0.94	113	226	340	453					
0.38	693	1385	2078	2770	0.95	111	222	332	443					
0.39	657	1315	1972	2630	0.96	109	217	326	434					
0.40	625	1250	1875	2500	0.97	106	213	319	425					
0.41	595	1190	1785	2380	0.98	104	208	312	416					
0.42	567	1134	1701	2268	0.99	102	204	306	408					
0.43	541	1082	1622	2163	1.00	100	200	300	400					
0.44	517	1033	1550	2066										
0.45	494	988	1481	1975										
0.46	473	945	1418	1890										
0.47	453	905	1358	1811										
0.48	434	868	1302	1736										
0.49	416	833	1249	1666										
0.50	400	800	1200	1600										
0.51	384	769	1153	1538										
0.52	370	740	1109	1479										
0.53	356	712	1068	1424										
0.54	343	686	1029	1372										
0.55	331	661	992	1322										
0.56	319	638	957	1276										
0.57	308	616	923	1231										
0.58	297	595	892	1189										
0.59	287	575	862	1149										
0.60	278	556	833	1111										
0.61	269	537	806	1075										
0.62	260	520	780	1041										
0.63	252	504	756	1008										
0.64	244	488	732	977										
0.65	237	473	710	947										
0.66	230	459	689	918										
0.67	223	446	668	891										
0.68	216	433	649	865										
0.69	210	420	630	840										
0.70	204	408	612	816										
0.71	198	397	595	793										
0.72	193	386	579	772										
0.73	188	375	563	751										
0.74	183	365	548	730										
0.75	178	356	533	711										
0.76	173	348	519	693										

Ordering sheet

For faster quote processing, please use the following request for ordering sheet. For each section, check the applicable box or enter value corresponding to your choice.

Request	Hitachi Industrial Equipment Systems Co., Ltd.		Order date			Distributor name
Project			Contractor			
Delivery place			Delivery date	P/L Maker		

ACB main body	Type of ACB	<input type="checkbox"/> A0H	<input type="checkbox"/> A0M 1)	<input type="checkbox"/> A0J	Quantity																																																																																																																																																																																								
	Frame type	<input type="checkbox"/> D (500-2000A) 1)	<input type="checkbox"/> F (2000-4000A)	<input type="checkbox"/> P (4000-5000A)	<input type="checkbox"/> Q (4000-6500A)																																																																																																																																																																																								
	Settings	AP																																																																																																																																																																																											
	Rated current (CT)	A																																																																																																																																																																																											
	Triple relay	<input type="checkbox"/> NO <input type="checkbox"/> YES																																																																																																																																																																																											
		<table border="1"> <thead> <tr> <th>Type</th> <th>Frequency</th> <th>Control voltage</th> <th>Comm.</th> <th>Optional function</th> </tr> <tr> <th></th> <th>50Hz</th> <th>50V</th> <th>No</th> <th>Earth leakage detection</th> </tr> </thead> <tbody> <tr> <td rowspan="10">H Normal</td> <td><input type="checkbox"/> H00</td> <td><input type="checkbox"/> H03</td> <td>*</td> <td>-</td> </tr> <tr> <td><input type="checkbox"/> A00</td> <td><input type="checkbox"/> A03</td> <td>-</td> <td>-</td> </tr> <tr> <td><input type="checkbox"/> A01</td> <td><input type="checkbox"/> A05</td> <td>-</td> <td>-</td> </tr> <tr> <td><input type="checkbox"/> A02</td> <td><input type="checkbox"/> A07</td> <td>-</td> <td>-</td> </tr> <tr> <td><input type="checkbox"/> A20</td> <td><input type="checkbox"/> A23</td> <td>*</td> <td>-</td> </tr> <tr> <td><input type="checkbox"/> A21</td> <td><input type="checkbox"/> A26</td> <td>-</td> <td>-</td> </tr> <tr> <td><input type="checkbox"/> A22</td> <td><input type="checkbox"/> A27</td> <td>-</td> <td>-</td> </tr> <tr> <td><input type="checkbox"/> A23</td> <td><input type="checkbox"/> A27</td> <td>-</td> <td>-</td> </tr> <tr> <td><input type="checkbox"/> A20</td> <td><input type="checkbox"/> A25</td> <td>-</td> <td>-</td> </tr> <tr> <td><input type="checkbox"/> A21</td> <td><input type="checkbox"/> A26</td> <td>-</td> <td>-</td> </tr> <tr> <td rowspan="10">A Annular</td> <td><input type="checkbox"/> A01</td> <td><input type="checkbox"/> A05</td> <td>*</td> <td>-</td> </tr> <tr> <td><input type="checkbox"/> A02</td> <td><input type="checkbox"/> A07</td> <td>-</td> <td>-</td> </tr> <tr> <td><input type="checkbox"/> A21</td> <td><input type="checkbox"/> A26</td> <td>-</td> <td>-</td> </tr> <tr> <td><input type="checkbox"/> A22</td> <td><input type="checkbox"/> A27</td> <td>-</td> <td>-</td> </tr> <tr> <td><input type="checkbox"/> A23</td> <td><input type="checkbox"/> A27</td> <td>-</td> <td>-</td> </tr> <tr> <td><input type="checkbox"/> A20</td> <td><input type="checkbox"/> A25</td> <td>-</td> <td>-</td> </tr> <tr> <td><input type="checkbox"/> A21</td> <td><input type="checkbox"/> A26</td> <td>-</td> <td>-</td> </tr> <tr> <td><input type="checkbox"/> A22</td> <td><input type="checkbox"/> A27</td> <td>-</td> <td>-</td> </tr> <tr> <td><input type="checkbox"/> A23</td> <td><input type="checkbox"/> A27</td> <td>-</td> <td>-</td> </tr> <tr> <td><input type="checkbox"/> A20</td> <td><input type="checkbox"/> A25</td> <td>-</td> <td>-</td> </tr> </tbody> </table>		Type	Frequency	Control voltage	Comm.	Optional function		50Hz	50V	No	Earth leakage detection	H Normal	<input type="checkbox"/> H00	<input type="checkbox"/> H03	*	-	<input type="checkbox"/> A00	<input type="checkbox"/> A03	-	-	<input type="checkbox"/> A01	<input type="checkbox"/> A05	-	-	<input type="checkbox"/> A02	<input type="checkbox"/> A07	-	-	<input type="checkbox"/> A20	<input type="checkbox"/> A23	*	-	<input type="checkbox"/> A21	<input type="checkbox"/> A26	-	-	<input type="checkbox"/> A22	<input type="checkbox"/> A27	-	-	<input type="checkbox"/> A23	<input type="checkbox"/> A27	-	-	<input type="checkbox"/> A20	<input type="checkbox"/> A25	-	-	<input type="checkbox"/> A21	<input type="checkbox"/> A26	-	-	A Annular	<input type="checkbox"/> A01	<input type="checkbox"/> A05	*	-	<input type="checkbox"/> A02	<input type="checkbox"/> A07	-	-	<input type="checkbox"/> A21	<input type="checkbox"/> A26	-	-	<input type="checkbox"/> A22	<input type="checkbox"/> A27	-	-	<input type="checkbox"/> A23	<input type="checkbox"/> A27	-	-	<input type="checkbox"/> A20	<input type="checkbox"/> A25	-	-	<input type="checkbox"/> A21	<input type="checkbox"/> A26	-	-	<input type="checkbox"/> A22	<input type="checkbox"/> A27	-	-	<input type="checkbox"/> A23	<input type="checkbox"/> A27	-	-	<input type="checkbox"/> A20	<input type="checkbox"/> A25	-	-	<table border="1"> <thead> <tr> <th>Type</th> <th>Frequency</th> <th>Control voltage</th> <th>Comm.</th> <th>Optional function</th> </tr> <tr> <th></th> <th>50Hz</th> <th>50V</th> <th>No</th> <th>Earth leakage detection</th> </tr> </thead> <tbody> <tr> <td rowspan="10">F Resistor motor</td> <td><input type="checkbox"/> F01</td> <td><input type="checkbox"/> F03</td> <td>*</td> <td>-</td> </tr> <tr> <td><input type="checkbox"/> F02</td> <td><input type="checkbox"/> F07</td> <td>-</td> <td>-</td> </tr> <tr> <td><input type="checkbox"/> F01</td> <td><input type="checkbox"/> F03</td> <td>-</td> <td>-</td> </tr> <tr> <td><input type="checkbox"/> F02</td> <td><input type="checkbox"/> F07</td> <td>-</td> <td>-</td> </tr> <tr> <td><input type="checkbox"/> F01</td> <td><input type="checkbox"/> F03</td> <td>-</td> <td>-</td> </tr> <tr> <td><input type="checkbox"/> F02</td> <td><input type="checkbox"/> F07</td> <td>-</td> <td>-</td> </tr> <tr> <td><input type="checkbox"/> F01</td> <td><input type="checkbox"/> F03</td> <td>-</td> <td>-</td> </tr> <tr> <td><input type="checkbox"/> F02</td> <td><input type="checkbox"/> F07</td> <td>-</td> <td>-</td> </tr> <tr> <td><input type="checkbox"/> F01</td> <td><input type="checkbox"/> F03</td> <td>-</td> <td>-</td> </tr> <tr> <td><input type="checkbox"/> F02</td> <td><input type="checkbox"/> F07</td> <td>-</td> <td>-</td> </tr> <tr> <td rowspan="10">S Synchronous motor</td> <td><input type="checkbox"/> S01</td> <td><input type="checkbox"/> S06</td> <td>*</td> <td>-</td> </tr> <tr> <td><input type="checkbox"/> S02</td> <td><input type="checkbox"/> S07</td> <td>-</td> <td>-</td> </tr> <tr> <td><input type="checkbox"/> S01</td> <td><input type="checkbox"/> S06</td> <td>-</td> <td>-</td> </tr> <tr> <td><input type="checkbox"/> S02</td> <td><input type="checkbox"/> S07</td> <td>-</td> <td>-</td> </tr> <tr> <td><input type="checkbox"/> S01</td> <td><input type="checkbox"/> S06</td> <td>-</td> <td>-</td> </tr> <tr> <td><input type="checkbox"/> S02</td> <td><input type="checkbox"/> S07</td> <td>-</td> <td>-</td> </tr> <tr> <td><input type="checkbox"/> S01</td> <td><input type="checkbox"/> S06</td> <td>-</td> <td>-</td> </tr> <tr> <td><input type="checkbox"/> S02</td> <td><input type="checkbox"/> S07</td> <td>-</td> <td>-</td> </tr> <tr> <td><input type="checkbox"/> S01</td> <td><input type="checkbox"/> S06</td> <td>-</td> <td>-</td> </tr> <tr> <td><input type="checkbox"/> S02</td> <td><input type="checkbox"/> S07</td> <td>-</td> <td>-</td> </tr> </tbody> </table>		Type	Frequency	Control voltage	Comm.	Optional function		50Hz	50V	No	Earth leakage detection	F Resistor motor	<input type="checkbox"/> F01	<input type="checkbox"/> F03	*	-	<input type="checkbox"/> F02	<input type="checkbox"/> F07	-	-	<input type="checkbox"/> F01	<input type="checkbox"/> F03	-	-	<input type="checkbox"/> F02	<input type="checkbox"/> F07	-	-	<input type="checkbox"/> F01	<input type="checkbox"/> F03	-	-	<input type="checkbox"/> F02	<input type="checkbox"/> F07	-	-	<input type="checkbox"/> F01	<input type="checkbox"/> F03	-	-	<input type="checkbox"/> F02	<input type="checkbox"/> F07	-	-	<input type="checkbox"/> F01	<input type="checkbox"/> F03	-	-	<input type="checkbox"/> F02	<input type="checkbox"/> F07	-	-	S Synchronous motor	<input type="checkbox"/> S01	<input type="checkbox"/> S06	*	-	<input type="checkbox"/> S02	<input type="checkbox"/> S07	-	-	<input type="checkbox"/> S01	<input type="checkbox"/> S06	-	-	<input type="checkbox"/> S02	<input type="checkbox"/> S07	-	-	<input type="checkbox"/> S01	<input type="checkbox"/> S06	-	-	<input type="checkbox"/> S02	<input type="checkbox"/> S07	-	-	<input type="checkbox"/> S01	<input type="checkbox"/> S06	-	-	<input type="checkbox"/> S02	<input type="checkbox"/> S07	-	-	<input type="checkbox"/> S01	<input type="checkbox"/> S06	-	-	<input type="checkbox"/> S02	<input type="checkbox"/> S07	-	-
	Type	Frequency	Control voltage	Comm.	Optional function																																																																																																																																																																																								
		50Hz	50V	No	Earth leakage detection																																																																																																																																																																																								
	H Normal	<input type="checkbox"/> H00	<input type="checkbox"/> H03	*	-																																																																																																																																																																																								
		<input type="checkbox"/> A00	<input type="checkbox"/> A03	-	-																																																																																																																																																																																								
<input type="checkbox"/> A01		<input type="checkbox"/> A05	-	-																																																																																																																																																																																									
<input type="checkbox"/> A02		<input type="checkbox"/> A07	-	-																																																																																																																																																																																									
<input type="checkbox"/> A20		<input type="checkbox"/> A23	*	-																																																																																																																																																																																									
<input type="checkbox"/> A21		<input type="checkbox"/> A26	-	-																																																																																																																																																																																									
<input type="checkbox"/> A22		<input type="checkbox"/> A27	-	-																																																																																																																																																																																									
<input type="checkbox"/> A23		<input type="checkbox"/> A27	-	-																																																																																																																																																																																									
<input type="checkbox"/> A20		<input type="checkbox"/> A25	-	-																																																																																																																																																																																									
<input type="checkbox"/> A21		<input type="checkbox"/> A26	-	-																																																																																																																																																																																									
A Annular	<input type="checkbox"/> A01	<input type="checkbox"/> A05	*	-																																																																																																																																																																																									
	<input type="checkbox"/> A02	<input type="checkbox"/> A07	-	-																																																																																																																																																																																									
	<input type="checkbox"/> A21	<input type="checkbox"/> A26	-	-																																																																																																																																																																																									
	<input type="checkbox"/> A22	<input type="checkbox"/> A27	-	-																																																																																																																																																																																									
	<input type="checkbox"/> A23	<input type="checkbox"/> A27	-	-																																																																																																																																																																																									
	<input type="checkbox"/> A20	<input type="checkbox"/> A25	-	-																																																																																																																																																																																									
	<input type="checkbox"/> A21	<input type="checkbox"/> A26	-	-																																																																																																																																																																																									
	<input type="checkbox"/> A22	<input type="checkbox"/> A27	-	-																																																																																																																																																																																									
	<input type="checkbox"/> A23	<input type="checkbox"/> A27	-	-																																																																																																																																																																																									
	<input type="checkbox"/> A20	<input type="checkbox"/> A25	-	-																																																																																																																																																																																									
Type	Frequency	Control voltage	Comm.	Optional function																																																																																																																																																																																									
	50Hz	50V	No	Earth leakage detection																																																																																																																																																																																									
F Resistor motor	<input type="checkbox"/> F01	<input type="checkbox"/> F03	*	-																																																																																																																																																																																									
	<input type="checkbox"/> F02	<input type="checkbox"/> F07	-	-																																																																																																																																																																																									
	<input type="checkbox"/> F01	<input type="checkbox"/> F03	-	-																																																																																																																																																																																									
	<input type="checkbox"/> F02	<input type="checkbox"/> F07	-	-																																																																																																																																																																																									
	<input type="checkbox"/> F01	<input type="checkbox"/> F03	-	-																																																																																																																																																																																									
	<input type="checkbox"/> F02	<input type="checkbox"/> F07	-	-																																																																																																																																																																																									
	<input type="checkbox"/> F01	<input type="checkbox"/> F03	-	-																																																																																																																																																																																									
	<input type="checkbox"/> F02	<input type="checkbox"/> F07	-	-																																																																																																																																																																																									
	<input type="checkbox"/> F01	<input type="checkbox"/> F03	-	-																																																																																																																																																																																									
	<input type="checkbox"/> F02	<input type="checkbox"/> F07	-	-																																																																																																																																																																																									
S Synchronous motor	<input type="checkbox"/> S01	<input type="checkbox"/> S06	*	-																																																																																																																																																																																									
	<input type="checkbox"/> S02	<input type="checkbox"/> S07	-	-																																																																																																																																																																																									
	<input type="checkbox"/> S01	<input type="checkbox"/> S06	-	-																																																																																																																																																																																									
	<input type="checkbox"/> S02	<input type="checkbox"/> S07	-	-																																																																																																																																																																																									
	<input type="checkbox"/> S01	<input type="checkbox"/> S06	-	-																																																																																																																																																																																									
	<input type="checkbox"/> S02	<input type="checkbox"/> S07	-	-																																																																																																																																																																																									
	<input type="checkbox"/> S01	<input type="checkbox"/> S06	-	-																																																																																																																																																																																									
	<input type="checkbox"/> S02	<input type="checkbox"/> S07	-	-																																																																																																																																																																																									
	<input type="checkbox"/> S01	<input type="checkbox"/> S06	-	-																																																																																																																																																																																									
	<input type="checkbox"/> S02	<input type="checkbox"/> S07	-	-																																																																																																																																																																																									
<p>Notes: Standard functions (Standard load selection)</p> <ul style="list-style-type: none"> * Communication function is not available with the control voltage - 400V ACB type is not available for 3-phase - F (Power) / S (synchronous) is also available for generator protection - S: Motor loads the economy (EPR) for voltage measurement 																																																																																																																																																																																													
No. of poles	<input type="checkbox"/> 3-pole		<input type="checkbox"/> 4-pole		<input type="checkbox"/> Standard type (R, S, T, X) <input type="checkbox"/> Reverse phase type (M, R, S, T)																																																																																																																																																																																								
Installation type	<input type="checkbox"/> Draw-out type		<input type="checkbox"/> Fixed type																																																																																																																																																																																										
Closing type	<input type="checkbox"/> Manual closing																																																																																																																																																																																												
	<input type="checkbox"/> Electric closing																																																																																																																																																																																												
	<input type="checkbox"/> Charge method: Charging completion contact (16) is basically installed <input type="checkbox"/> Motor operating voltage: <input type="checkbox"/> AC/DC 100V - 120V <input type="checkbox"/> AC/DC 200V - 250V <input type="checkbox"/> DC 120V <input type="checkbox"/> DC 20V - 30V <input type="checkbox"/> DC 40V - 60V		<input type="checkbox"/> Standard type (OFF Charge method) <input type="checkbox"/> Rapid auto-resetting type (ON Charge method)																																																																																																																																																																																										
Closing voltage	<input type="checkbox"/> AC/DC 100V - 120V <input type="checkbox"/> DC 120V		<input type="checkbox"/> AC/DC 200V - 250V <input type="checkbox"/> DC 20V - 30V		<input type="checkbox"/> DC 40V - 60V <input type="checkbox"/> DC 40V - 60V <input type="checkbox"/> AC 380V - 480V <input type="checkbox"/> DC 40V - 60V <input type="checkbox"/> AC 380V - 480V <input type="checkbox"/> AC 48V																																																																																																																																																																																								
Trip voltage	<input type="checkbox"/> AC/DC 100V - 120V <input type="checkbox"/> DC 120V		<input type="checkbox"/> AC/DC 200V - 250V <input type="checkbox"/> DC 20V - 30V		<input type="checkbox"/> DC 40V - 60V <input type="checkbox"/> AC 380V - 480V <input type="checkbox"/> AC 48V																																																																																																																																																																																								
Cradle type	<input type="checkbox"/> No safety shutoff (F class)																																																																																																																																																																																												
Terminal connection	<input type="checkbox"/> Manual connection <input type="checkbox"/> Automatic connection																																																																																																																																																																																												
Connections	<input type="checkbox"/> Horizontal		<input type="checkbox"/> Vertical		<input type="checkbox"/> Front connection																																																																																																																																																																																								
	<input type="checkbox"/> Line/Horizontal, Load/Vertical		<input type="checkbox"/> Line/Vertical, Load/Horizontal		<input type="checkbox"/> Separate order/User installation																																																																																																																																																																																								

ACB accessory	ACB Main body	Standard accessory	Aux. contact (AK)	<input type="checkbox"/> Standard type (3x1s, standard installation)	<input type="checkbox"/> Extended type (3x1s) 1)	<input type="checkbox"/> High capacity (3x1s) 1)	
			Key Lock (K1, K3)	<input type="checkbox"/> Single key, K1 (ON - Lock)		<input type="checkbox"/> Double key, K3 (ON - Lock)	
			Under voltage trip device (UYT, Instantaneous)				
			<input type="checkbox"/> AC/DC 100V - 120V <input type="checkbox"/> AC/DC 200V - 250V <input type="checkbox"/> DC 120V	<input type="checkbox"/> DC 20V - 30V <input type="checkbox"/> DC 40V - 60V		<input type="checkbox"/> AC/DC 380V - 480V <input type="checkbox"/> AC 48V	
			Mechanical operation contact (MOQ, Door Interlock (DI))	<input type="checkbox"/> Non-attachment type		<input type="checkbox"/> Attachment type	
			Mechanical interlock (MI)	<input type="checkbox"/> Non-attachment type		<input type="checkbox"/> Attachment type	
			Counter (C) 1)	<input type="checkbox"/> Non-attachment type		<input type="checkbox"/> Attachment type	
			Miss insertion preventive device (MIP)	<input type="checkbox"/> Non-attachment type		<input type="checkbox"/> Attachment type	
			Double shunt coil (SH2)	<input type="checkbox"/> Non-attachment type		<input type="checkbox"/> Attachment type	
			Ready-to-close switch (RCS)	<input type="checkbox"/> Non-attachment type		<input type="checkbox"/> Attachment type	
Trip alarm switch, Manual reset button (AL, MRB)	<input type="checkbox"/> Non-attachment type		<input type="checkbox"/> Attachment type				
<input type="checkbox"/> Key interlock (K2, ON - Lock)	<input type="checkbox"/> Temperature Alarm						
ACB cable	Standard accessory	<input type="checkbox"/> Safety shutoff lock (STL)					
		<input type="checkbox"/> Zero amp space (ZAS) 1)					
Separate purchase		Main body mounting	<input type="checkbox"/> Insulation barrier (IB)				
			<input type="checkbox"/> Slow closing limit (SL)				
			<input type="checkbox"/> Call switch (CL)		<input type="checkbox"/> DC		
			<input type="checkbox"/> Door interlock (DI)				
			<input type="checkbox"/> Mechanical operation contact (MOQ)		<input type="checkbox"/> Standard type (16A10s)		<input type="checkbox"/> High capacity (16A10s)
			<input type="checkbox"/> Mechanical interlock (MI)		<input type="checkbox"/> Wire type (2 terminals)		<input type="checkbox"/> Wire type (3 terminals)
			<input type="checkbox"/> Shortening to-contact (SBC, 4s Max)		<input type="checkbox"/> 2s		<input type="checkbox"/> 4s
			<input type="checkbox"/> Miss insertion preventive device (MIP)		<input type="checkbox"/> Non-attachment type		<input type="checkbox"/> Attachment type
	<input type="checkbox"/> Cradle mounting block (CMB)		<input type="checkbox"/> Safety control cover (SC)				
	<input type="checkbox"/> Locking interlock (LI)		<input type="checkbox"/> Insulation barrier (IB) 1)				
	External mounting	<input type="checkbox"/> UYT time delay controller (UGC)					
		<input type="checkbox"/> AC/DC 100V - 120V <input type="checkbox"/> AC/DC 200V - 250V <input type="checkbox"/> DC 120V		<input type="checkbox"/> DC 40V - 60V <input type="checkbox"/> AC 380V - 480V <input type="checkbox"/> AC 48V			
		<input type="checkbox"/> Door frame (DF)		<input type="checkbox"/> Contactor trip device (CTD)			
		<input type="checkbox"/> Dual cover (DC)		<input type="checkbox"/> Red/blue DP Contact (RC)			
			<input type="checkbox"/> Temperature Alarm (TA)		<input type="checkbox"/> Remote I/O (RCD)		

1) In case of D type of ACB, these size is in the range of 600 - 1000A

2) The standard accessory for ACB

3) Lock contact with extended high capacity type adapts the rapid auto-resetting method and available up to 16A.

● **Headquarters**

AKS Building, 3, Kanda Neribeicho,
Chiyoda-ku, Tokyo, 101-0022, Japan
TEL: <81>(3)4345-6000
FAX: <81>(3)4345-6914

● **Singapore**

Hitachi Asia Ltd.
Power & Industrial Systems Group
24 Jurong Port Road, #03-05 Cwt Distripark,
Office Block, Singapore, 619097
TEL: <65>(6305)7400
FAX: <65>(6305)7401

● **Vietnam**

Hitachi Asia Ltd.(Ho Chi Minh City Office)

7th Floor, The Landmark, 5B Ton Duc Thang
Street District 1, Ho Chi Minh City
TEL: <84>(8)829-9725
FAX: <84>(8)829-9729

(Ha Noi Office)

Sun Red River Bldg, 6th Floor,
23 Phan Chu Trinh Street
Hoan Kiem District Hanoi
TEL: <84>(4)933-3123
FAX: <84>(4)933-3125

● **India**

Hitachi India Trading Pvt. Ltd.

Hindustan Times House (10th Floor)
18-20, Kasturba Gandhi Marg., New Delhi, 110001
TEL: <91>(11)331-5635, 371-2817, -3953, -3958
FAX: <91>(11)331-3742

● **Indonesia**

Hitachi Asia Ltd. (Jakarta Office)

Mid Plaza 1, 10th Floor, J.J. Jend.
Sudirman Kav. 10-11, Jakarta 10220
TEL: <62>(21)574-4313
FAX: <62>(21)574-4312

● **Malaysia**

Hitachi Asia (Malaysia) Sdn. Bhd.

Suite 17.3, Level 17, Menara IMC (Letter Box No.5)
No. 8 Jalan Sultan Ismail, 50250, Kuala Lumpur
TEL: <60>(3)201-8751
FAX: <60>(3)201-8757, -8758

● **Philippines**

Hitachi Asia Ltd. (Philippines Branch)

25th Floor, Pacific Star Building, Cor. Makati & Sen. Gil.
Puyat Ave., Makati, Metro Manila
TEL: <63>(2)819-7528, -7529
FAX: <63>(2)819-7539

● **Thailand**

Hitachi Asia (Thailand) Co., Ltd.

18th Floor, Ramaland Building, 952 Rama IV Road
Bangrak, Bangkok 10500
TEL: <66>(2)632-9292
FAX: <66>(2)632-9299

● **China**

Hitachi East Asia Ltd.

4th Floor, North Tower
World Finance Centre, Harbour City
Canton Road, Tsim Sha Tsui, Kowloon
Hong Kong
TEL: <852>2735-9218
FAX: <852>2735-3192

Hitachi China Ltd. (Beijing Office)

Room 1412, Beijing Fortune Building
5 Dong San Huan Bei Lu
Chao Yang District, Beijing 100004
TEL: <86>(10)6590-8851, -8852, -8853, -8854
FAX: <86>(10)6590-8850

Hitachi (Shanghai) Trading Co., Ltd.

18th Floor, Rui Jin Building,
No.205, Maoming Road(S)
Shanghai, 200030
TEL: <86>(21)6472-1002
FAX: <86>(21)6415-8272

● **Taiwan**

Taiwan Hitachi Asia Pacific Co., Ltd.

3rd Floor, Hung Kuo Building No.167
Tun-Hwa North Road, Taipei (105), Taiwan
TEL: <886>(2)2718-3666
FAX: <886>(2)2718-8180

Information in this brochure is subject to change without notice.

 **Hitachi Industrial Equipment Systems Co., Ltd.**

<http://www.hitachi-ies.co.jp/english/index.htm>

For further information, please contact your nearest sales representative.